

Wheel Measurement

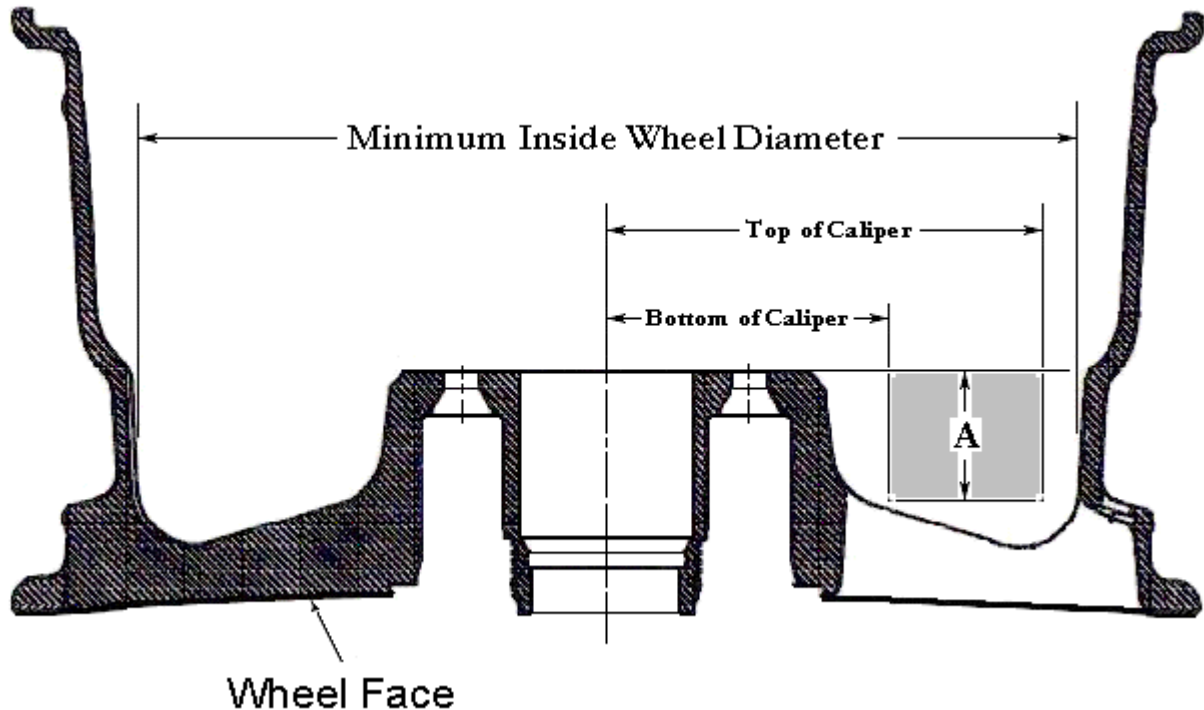

<u>Rotor Diameter</u>	<u>"A" Dimension</u>	<u>Bottom of Caliper</u>	<u>Top of Caliper</u>
380 mm (15.0") Front	14 mm (0.6")	123 mm (4.8")	228 mm (9.0")

Example: 15" Front Kit 1J1.9001A for Chevy & GMC 2500 Trucks

- With a straight edge measure from the middle of the center bore out to 123 mm for the Kit to locate the bottom of the caliper.
- Now measure down from the straight edge to the back of the wheel spoke for the Kit's "A" measurement. **The Kit needs 14 mm or more for the "A" dimension** to clear the caliper.
- Repeat these (2) steps for the caliper clearance through to the top of the caliper.