



WP29 and WP32 Electric Water Pump

Installation Manual and Installation Approval Documentation



This manual is effective for aftermarket and OEM installations of the following part and serial numbers:

Part Number	Serial Number(s)
1030085xxx	All
1030002xxx	All

Rev	Rev By	Date	Description of Change	Approved By
A	MPL/BF	4/9/13	Original Release	ECN2805
C	BF	10/30/13	Formatting, Orientation, Checklist	ECN3149

Engineered Machined Products Inc.

2701 North 30th Street
Escanaba, Michigan 49829

Phone: 906-789-7497

www.emp-corp.com

Service@emp-corp.com

Product Overview

The WP29 and WP32 are electrically powered fluid pumps available in 12 volt DC and 24 volt DC configurations. The pump is available with carbon steel, or stainless steel shafts for fluid compatibility. Proper installation of the pump will help ensure the performance and reliability of the electric pump while reducing the risk of damage to other components in the system.

This document provides a check list to confirm that the pump and the installation of the pump fall within the hardware and operational capabilities of the pump. If there are parameters outside the normal application, additional information will be required for EMP Engineering to approve the installation or warranty will be void.

Use the Installation Approval check sheet located in Appendix B to submit installation information to EMP for approval.

The information contained in this manual is updated periodically. While great care is taken in compiling the information contained in this manual, Engineered Machined Products, Inc. cannot assume liability for losses of any nature arising from any errors and/or omissions.

The information and specifications contained throughout this manual are up to date at the time of publication. Engineered Machined Products, Inc. reserves the right to change the content of this manual at any time without notice.

Product Overview	2
Safety.....	4
Warnings, Cautions & Notes.....	4
Product Safety Warnings	4
Purpose.....	5
Development Engineer Responsibilities.....	5
Specifications.....	6
Dimensions.....	6
Hole Locations/Bolt Spacing.....	6
Material Listing of Major External and Fluid Contacting Parts	7
Performance	9
Pump Performance Curves	9
Pump Limitations	10
Temperatures	10
Vibration	10
Environment	10
Orientation	10
Inlet and Outlet Pressures	11
Fluid Level	12
Approved Coolants	12
Supplementary Coolant Additives (SCA)	12
Plumbing.....	13
Recommended Plumbing	13
Electrical Specifications and Requirements.....	14
Schematics.....	15
Mating Connectors.....	15
Wiring.....	16
Wire Sizing	16
Recommended Wiring Practices.....	16
Installation.....	17
Orientation Specific.....	17
Dual Orientation.....	18
Incorrect Pump Orientation and Reasons.....	18
Physical Inspection	19
Troubleshooting	20
EMPower Connect™ Service Tool.....	20
Appendix A, WP29 and WP32 Installation Testing	21
Equipment Required for WP29 and WP32 Data Collection	21
Inlet Pressure Measurement Test Procedure	22
Test Data Log Sheet.....	24
Appendix B, WP29 and WP32 Installation Approval Registration and Check Sheet.....	26
Installation Approval #	26
Product Installation Questionnaire.....	27

Safety

Warnings, Cautions & Notes

Three types of headings are used in this manual to stress your safety and safe operation of the WP29. They appear in the text as follows:

 **WARNING:**
THIS SYMBOL IS USED TO MAKE YOU AWARE OF AN UNSAFE CONDITION, HAZARD, OR PRACTICE THAT CAN RESULT IN PERSONAL INJURY OR DEATH.

 **CAUTION:**
THIS SYMBOL IS USED TO ALERT YOU TO A CONDITION OR PRACTICE THAT CAN CAUSE DAMAGE TO THE WP29 AND WP32 OR THE VEHICLE, OR BOTH.

 **NOTE:** *Is used to provide additional information that requires special attention by the technician.*

Product Safety Warnings

 EMP cannot anticipate every possible circumstance that might involve a potential hazard. The safety messages in this document, in related manuals, and on the product are therefore not all inclusive. If a tool, procedure, work method, or operating technique that not specifically recommended by EMP is used, you must satisfy yourself that it is safe for you and for others. You should ensure that the product will not be damaged or be made unsafe by the operation, maintenance, or repair procedures that you choose.

 Ensure that all safety message and information messages are read and understood before installation, maintenance, or any repairs are performed. The person who services the product may be unfamiliar with many of the systems on the product. It is important to use caution when service work is performed. Knowledge of the vehicle system and operation are important before the removal or disassembly of any component.

 Make sure the vehicle is in neutral, the parking brake is set, and the wheels are blocked before doing any work or diagnostic procedures on the WP29 and WP32, or vehicle.

 Disconnect the main negative battery cable and/or switch the battery disconnect switch to the OFF position first before installation or servicing.

 Use extreme caution when working on systems under pressure (i.e. coolant, hydraulic fluids, air, etc...)

 Make sure the work area is ventilated and well lit.

 Make sure charged fire extinguishers are in the work area.

 Reinstall all safety guards, shields, and covers after servicing the vehicle.

 Make sure all tools, parts, and service equipment are removed from the engine compartment and vehicle after all work is done.

 Do not apply power to the pump without fluid since most pumps are programmed to start when power is applied and the pump seal will be damaged if run dry.

 If CAN or Serial TTL control is not used the 6 pin DTM connector must be blocked off to prevent entry of water or dirt which will result in damage to the pump. A block off plug EMP P/N 3250001030 can be purchased or one can be fabricated from the Deutsch parts listed in the table on page 12

Purpose

The purpose of the WP29 and WP32 installation manual is to present information related to the pump's dimensions, electrical specifications, flow and pressure capabilities, coolant guidelines, recommended plumbing, and system testing. This manual also outlines the WP29 and WP32 limitations that should be recognized and adhered to.

Development Engineer Responsibilities

The organization responsible for incorporating the WP29 and WP32 pump into any system must read and understand the requirements and specifications as explained in this manual. At any time during system development, EMP will participate in a design review if requested. Prior to production release of any system incorporating the WP29 and/or WP32, please take the time to fill out the included product installation registration form and e-mail to service@emp-corp.com.

EMP engineering will review the intended installation and will contact you if there are any issues seen in the information provided. It is up to the design engineer to ensure that all requirements are met; failure to do will void product warranty.

Specifications

Dimensions

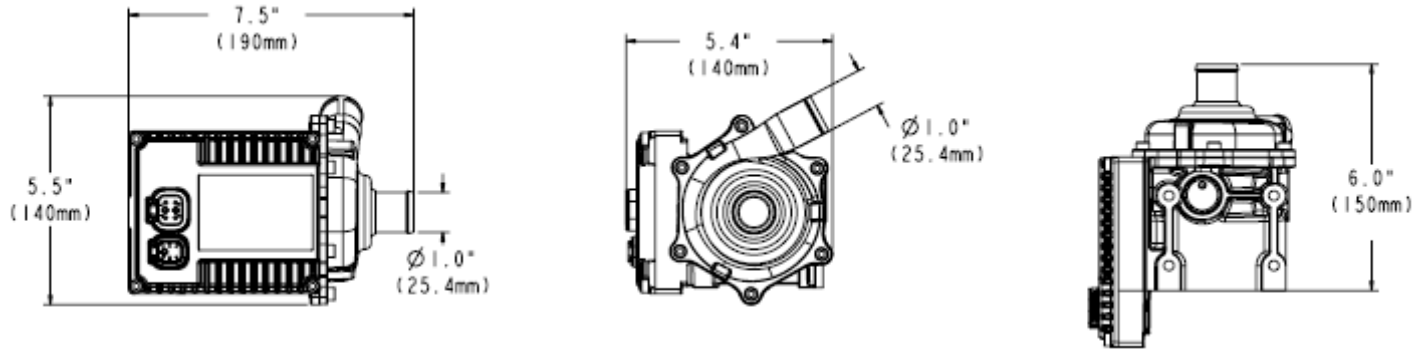

Hole Locations/Bolt Spacing

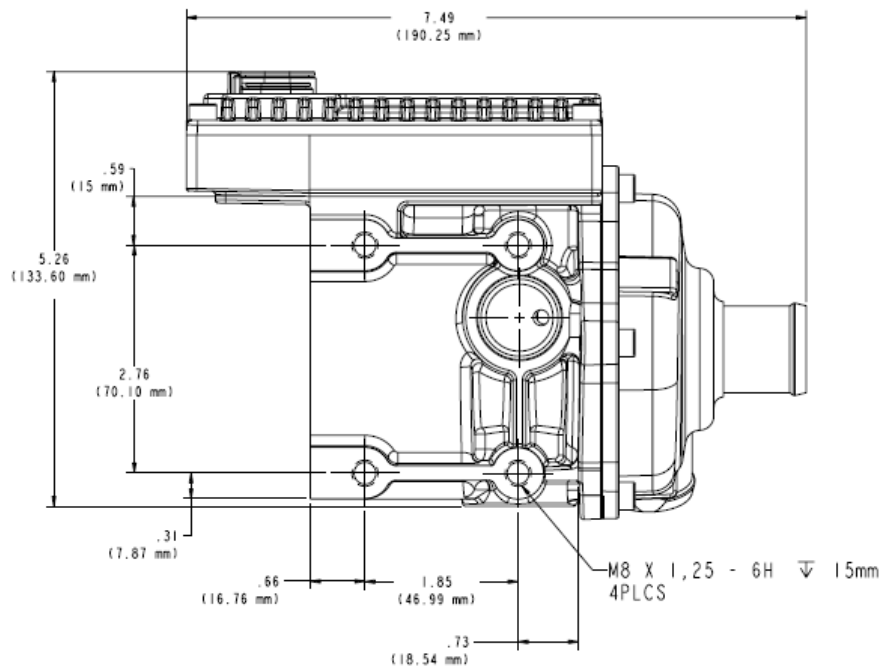

Material Listing of Major External and Fluid Contacting Parts

Item	Quantity	Description	Material	Fluid Contact
1	1	Cover	Cast Aluminum (413)	
2	1	Housings	Cast Aluminum (413)	YES
3	10	Bolt	18 – 8 Stainless Steel	
4	1	Volute	Cast Aluminum (413)	YES
5	1	Impeller (Internal)	304 Stainless Steel	YES
6	1	Shaft	1020 Carbon Steel	YES
7	1	Product Label	M - 714	
8	2	Connector	Dupont Zytel Nylon 70G33L	

NOTE: SAE 440 Stainless Steel Shafts are offered as an option on EMP WP29 and WP32 Pumps. Contact customer service for part number information.

Identification

The product identification labels are attached to the controller housing next to the electrical interface of the pump. The pump hardware part and serial numbers are located on the upper label. The lower label identifies the Programmed Assembly number and the associated control software as the pump leaves the manufacturing facility. The EMP service tool can be used to confirm the pump software should calibration changes be required and new identification tags issued.



Label Details

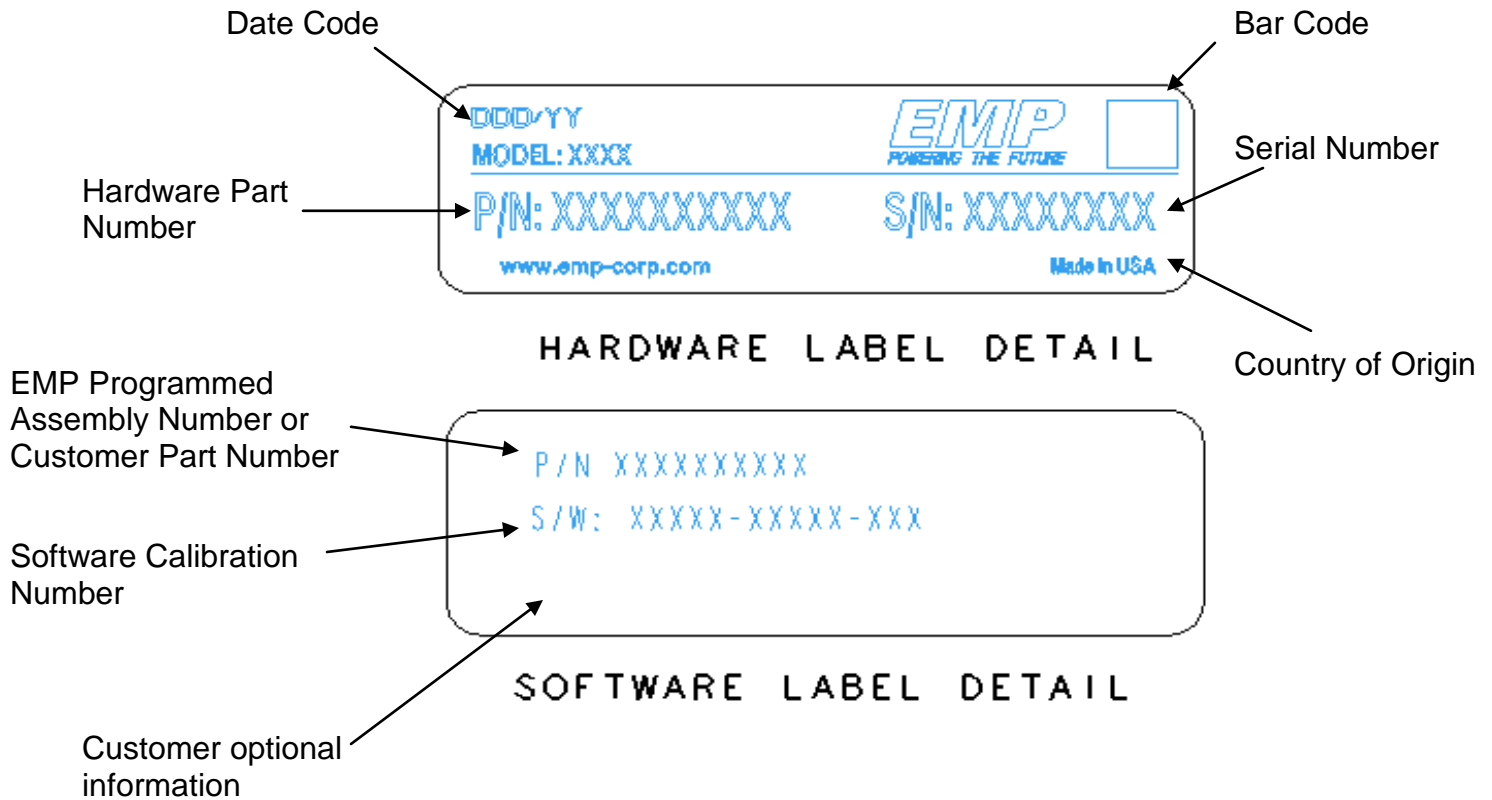

Performance

Pump Performance Curves

The pump performance curves shown in the illustrations below outline the maximum capability of the pump at maximum speed of the pump. Following the installation guidelines will result in peak performance matching the illustrated operation. Pump speed reduction will reduce the output capability.

The static pressure curve represents the pressure rise across the pump for a given flow. If the inlet pressure of the pump is negative, the outlet pressure of the pump is reduced by the inlet suction. Be aware of this situation in systems with little or no head pressure on the system.

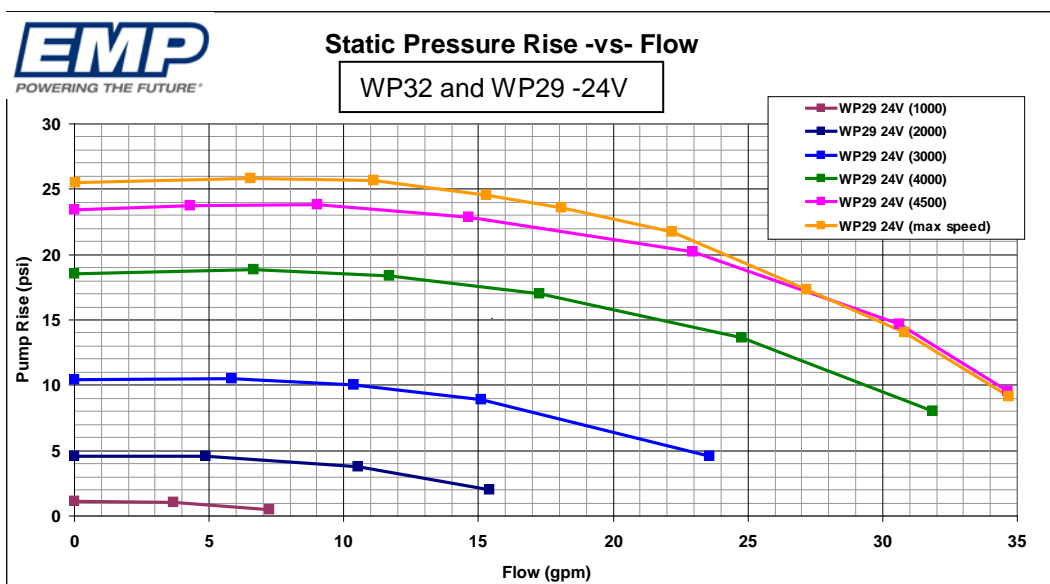
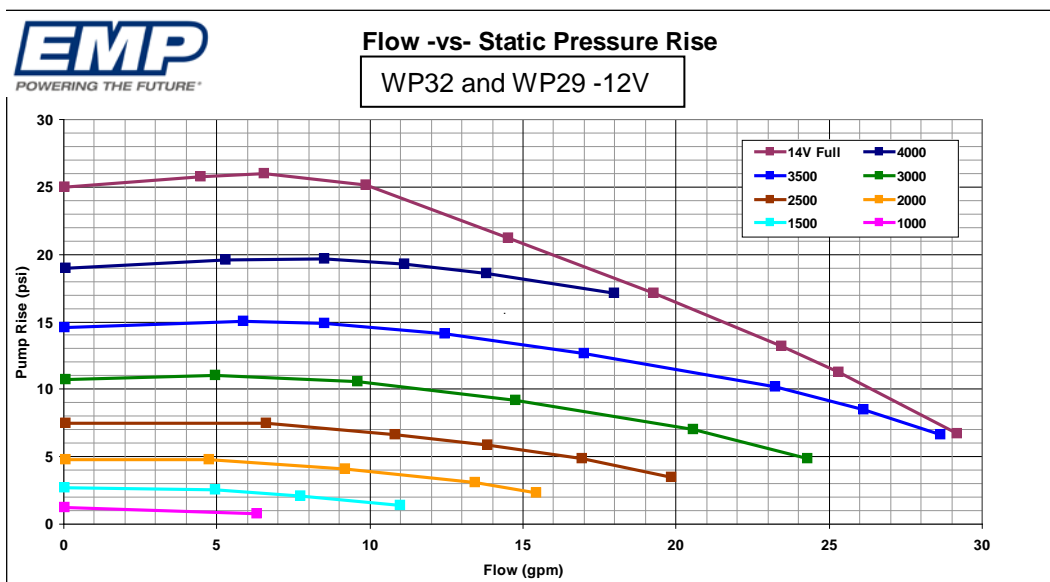

Pump Limitations

Temperatures

Table 1: Temperature Limitations

Maximum Fluid and Ambient Operating Temp	203°F (95°C)*
Minimum Fluid and Ambient Operating Temp	-40°F (-40°C)
Maximum Ambient Storage Temp	257°F (125°C)
Minimum Ambient Storage Temp	-40°F (-40°C)

* If the intended application fluid temperature exceeds 95°C, installation must be reviewed and approved by EMP to ensure warranty coverage. See Appendix A for the Installation Approval checklist.

NOTE: Over-temperature Protection

If the internal electronics operating temperature exceeds 266°F (130°C) the pump will shut off and stay off until the temperature drops to 257°F (125°C). At 95°C fluid temperature the pump controller is operating near the 130°C electronics temperature threshold.

Vibration

Vibration exceeding the EMPTS009 profile can shorten pump life, potentially leading to PCB and motor shaft failures. If you are unsure of your vibration profile for a given installation please contact EMP to ensure warranty coverage.

Environment

Environment cleanliness is crucial to pump life. The WP29 and WP32 are certified with an IP67 rating but debris collection in the weep pocket can lead to premature seal failure (See figure below). Shielding may be required to ensure debris does not enter the weep hole. If you have any questions regarding your installation contact EMP to ensure warranty coverage.

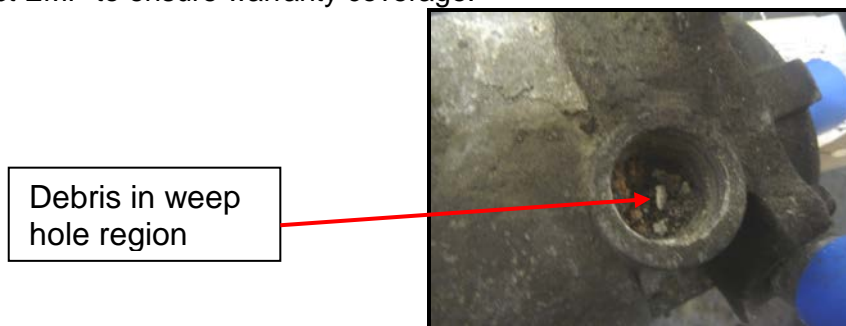

Orientation

Each pump part number has a specified and approved orientation. If the pump is not properly installed several failure modes could potentially result. Please reference the Pump Orientation section of this document for installation guidelines. If you have any questions regarding pump orientation please contact EMP to ensure warranty coverage.

Inlet and Outlet Pressures

Inlet Pressure/Configuration

- The WP29 and WP32 pumps must maintain an inlet pressure greater than -5 psi (-35kPa gauge) at the set WP29 and WP32 operating speed under all operating conditions

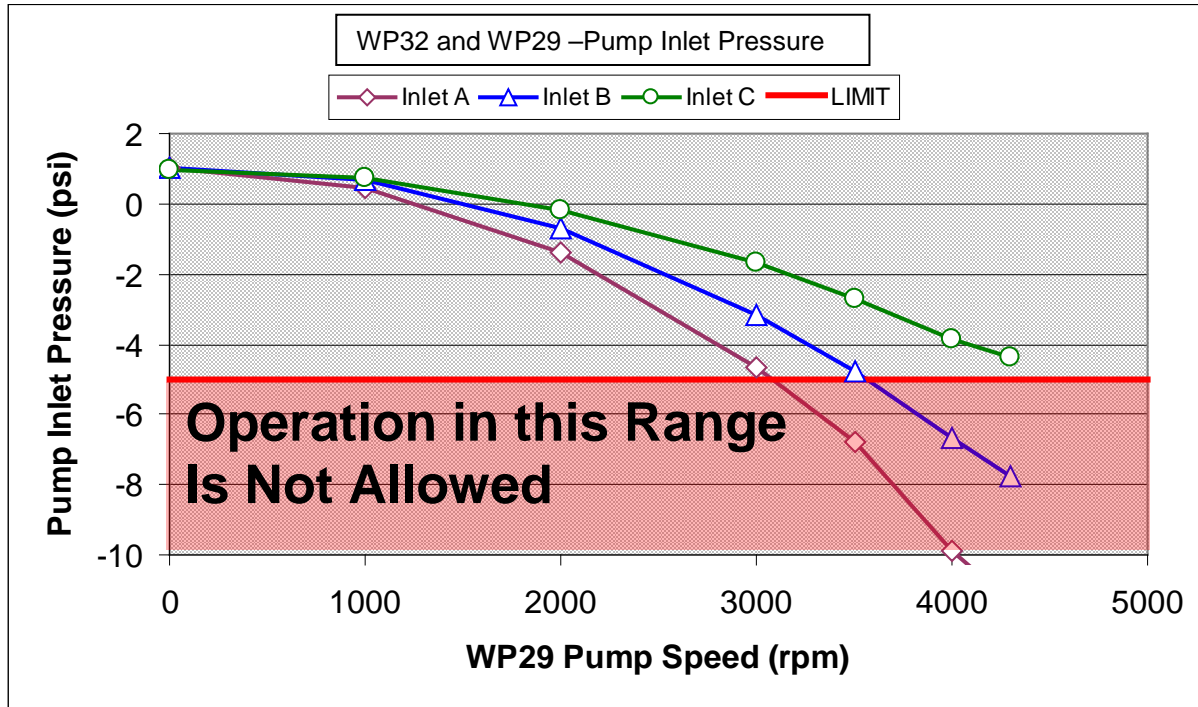

In the WP29 and WP32 Pump Inlet Pressure Map, three inlet configurations are illustrated. “Inlet A” configuration represents an inlet that is very restrictive, and any pump operation above 3000 pump rpm will violate the minimum inlet pressure requirement. The configuration will be forced to have a 3000 rpm pump speed limit. “Inlet B” is also restrictive, and will require the WP29 and WP32 pump speeds to be limited to 3500 rpm, where “Inlet C” remains in the safe operating zone for all measured pump speeds and has no special limitations.

If the application has low outlet restriction, the pump is current limited and may not be able to reach the anticipated pump speed. This speed limitation is a result of the motor controller protecting the electronics from a condition where excessive heat may build up in the controller.

Fluid Level



CAUTION: DO NOT RUN THE PUMP WITHOUT FLUID PRESENT. IF RUN DRY EVEN FOR A SHORT PERIOD THE SEAL WILL BE DAMAGED.

Approved Coolants

Heavy Duty Engines using Fully Formulated Coolant: Reference ASTM D6210 -10 for coolant quality and maintenance schedules. Test method references are listed in this specification

Light Duty Partial Formulated Coolant: Reference ASTM D3306 for coolant quality and maintenance schedules.

Based on field testing and experience, the WP29 and WP32 are compatible with the following coolant types:

1. Ethylene Glycol
2. HOAT (Hybrid Organic Acid Technology)
3. OAT (Organic Acid Technology)
4. Propylene Glycol

NOTE: - Use distilled water to dilute coolant or use pre-mix coolant

Supplementary Coolant Additives (SCA)

Coolant additives are allowed with the WP29 and WP32 water pump. The additive must be compatible with the base coolant and all contact surfaces of the pump. The additive concentration must be within the additive manufacturer's specification. Damage to the WP29 and WP32 or the system will not be warranted if the additive is not compatible with the base coolant or the concentration is outside manufacturer recommendations.



CAUTION: CONTACT CUSTOMER SERVICE TO VERIFY THAT COOLANTS NOT LISTED ABOVE ARE COMPATIBLE WITH PUMP COMPONENTS AND COMPLETE THE INSTALLATION APPROVAL FORM. WHEN USING A COOLANT THAT IS NOT APPROVED, THE INSTALLATION MUST BE EMP APPROVED



CAUTION: USE OF "STOP LEAK" STYLE SYSTEM ADDITIVES ARE NOT APPROVED



CAUTION: MIXING OF COOLANTS CAN CAUSE PROBLEMS WITH THE COOLING SYSTEM. FLUIDS CAN INTERACT RESULTING IN DAMAGE TO THE COOLING SYSTEM AND PUMP

Plumbing

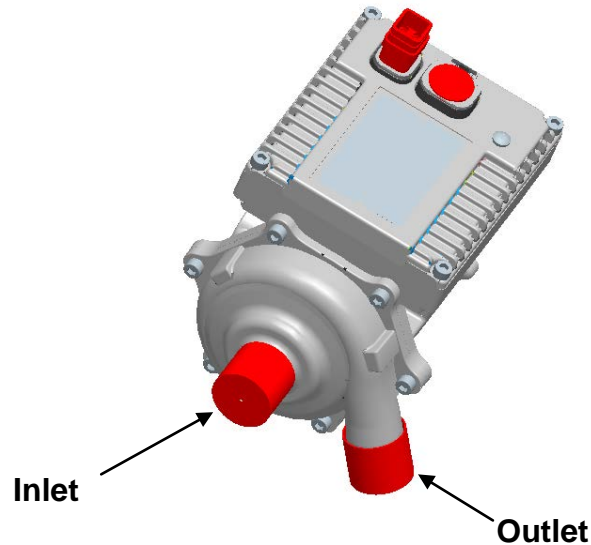

Recommended Plumbing

Pump Inlet must be plumbed using 25mm (1.0 inch) diameter hose and/or thin walled tubing from the fluid supply to the pump inlet.

A restriction in the inlet plumbing is allowed as long as the flow diameter is not less than 17mm (0.75 inch) and does not exceed 25mm (1.0 inch) in length.

Deviations from the Recommended Plumbing must meet the Inlet Requirements and be approved by EMP Engineering. Please contact EMP customer service for installation review.

Mounting Screws

Mounting screws used should be M8 x 1.25 screws (qty=4). These must have a minimum thread engagement of 0.50 inch (12.7 mm) and be tightened to a torque of **15 ft-lb (20N-m)**.



CAUTION: THE MOUNTING HOLES ARE TAPPED TO A DEPTH OF 0.59 INCHES (15MM). BE AWARE OF THE BRACKET THICKNESS WHEN SELECTING THE FASTENER LENGTH TO ENSURE THAT THE FASTENER WILL NOT BOTTOM OUT IN THE PUMP HOUSING.

Hose Clamps

When making the inlet and outlet hose connections to the pump it is strongly recommended to use SAE20CT worm drive type hose clamps. Torque worm drive clamps to 45 in-lbs per SAE J1508. Spring type clamps are not recommended.

Electrical Specifications and Requirements

Vehicle Battery Parameters

12V Pump				
Parameter	Min	Nom	Max	Units
Vin – Operating	9.0	13.5	16	V
Operating current	-	-	25 ⁽¹⁾⁽²⁾	A
Ignition off current	-	-	300	µA
Motor off current	-	80	-	mA
Inrush current	-	-	205 ⁽³⁾	A
Inrush current duration	-	-	270	µS
24V Pump				
Parameter	Min	Nom	Max	Units
Vin – Operating	18	27.0	32	V
Operating current	-	-	15 ⁽¹⁾⁽²⁾	A
Ignition off current	-	-	300	µA
Motor off current	-	60	-	mA
Inrush current	-	-	370 ⁽³⁾	A
Inrush current duration	-	-	250	µS

(1): Peak current is based on the software current limit. 25 amps is the standard current limit for a 12V pump and 15 amps is the standard current limit for a 24V pump for serial numbers > 07065826.

(2): The pump shuts down when the internal controller temperatures reaches 130°C at this point the pump will stop running until the internal controller temperature drops below 125°C. Once the safe value is reached, the pump will restart. No ignition cycle is required to restart the pump.

(3): The inrush current occurs when the controller first receives the required voltage on the ignition pin. This current inrush is due to the charging of the bulk capacitors in the controller. The inrush current numbers are worst case. They were measured with a battery as the source with a harness that was 3ft in length (very low source impedance). Anything done in the application to increase the source impedance will have a significant (downward) impact on these numbers. This current is not generated every time the motor is started, but only when the ignition line is first applied.

Vehicle Ignition Parameters

Parameter	Min	Nom	Max	Unit
Vin	9	13.5 or 27	32	V
IGN Current (13.5v)	-	2.5	-	mA
IGN Current (27.5v)	-	4	-	mA
Vin – Low (sleep)	-50	0	1	V

Schematics

1 – CANH
2 – CAN SHIELD
3 – SERIAL GND
4 – SERIAL TX
5 – SERIAL RX
6 – CANL

1 – TEMP INPUT OR CAN ADDRESS
2 – GND
3 – BATT
4 – IGNITION

NOTE: These represent the controller connectors – not the mating harness connectors.

NOTE: Addressing and motor status message information can be found in our J1939 Motor Control Document, 9980010068

Controller Connectors

Mating Connectors

The mating connectors and pins are available from EMP in kit #3170001077 for the 6 pin and #3170001078 for the 4 pin connector.

⚠ IF CAN OR SERIAL TTL CONTROL IS NOT USED THE 6 PIN DTM CONNECTOR MUST BE BLOCKED OFF TO PREVENT ENTRY OF WATER OR DIRT WHICH WILL RESULT IN DAMAGE TO THE PUMP. A BLOCK OFF PLUG, EMP P/N 3250001030 CAN BE PURCHASED.

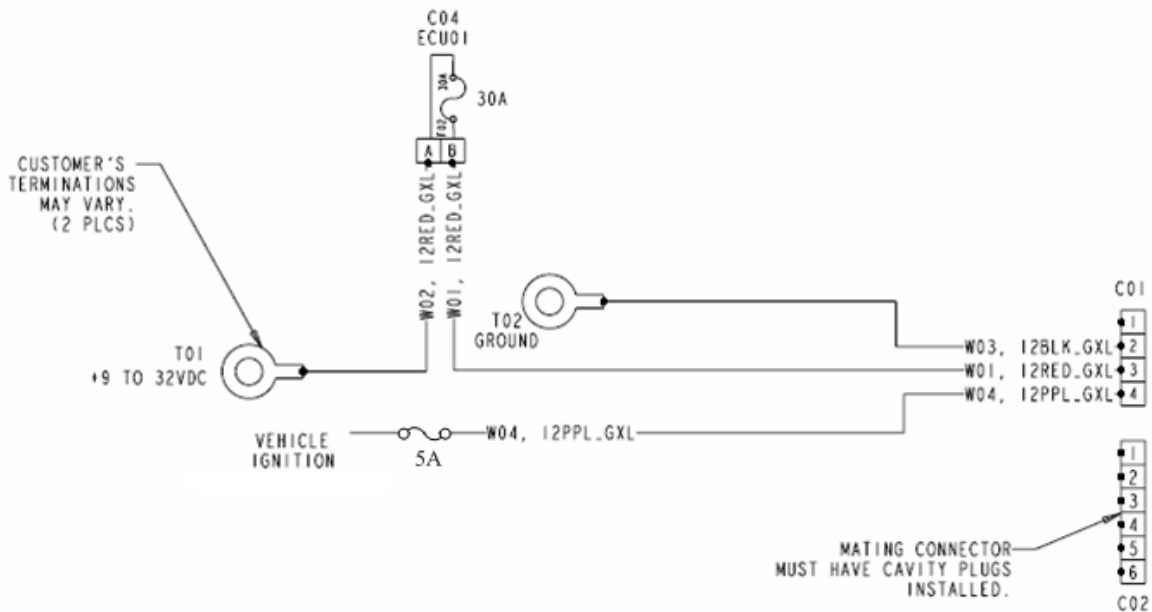

Sample Wiring Schematic

Wiring

Wire Sizing

- For complete connector body sealing the ignition wire should be 16ga minimum and the power and ground wires should be 12ga minimum

Recommended Wiring Practices

- Wiring or electrical harness must not rub on sharp edges.
- The electrical harness should not be stressed at connections (see Figure below)

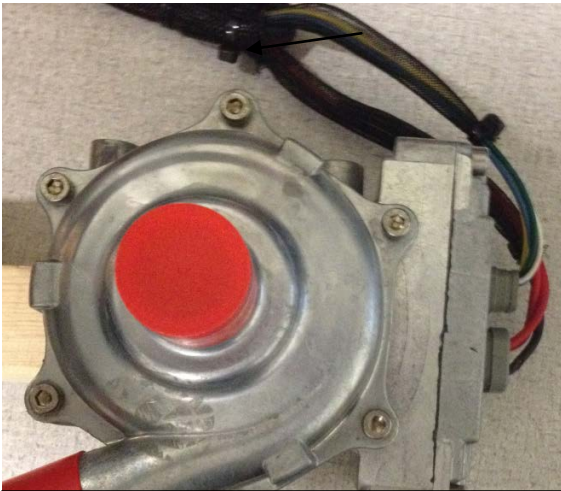

Wires pulling on connectors can compromise the connector body seal and possibly create a water intrusion event

- The voltage drop between the battery and the fan should not exceed 5% of the rated battery voltage. This should be verified at the pump's maximum current draw. Wiring or electrical harness must not rub or make contact with a hot surface. There should be 5" minimum clearance from the exhaust.
- Wiring or electrical harness should be supported at least every 18" to 20".
- To avoid possible fire or shock, do not pinch any wiring or electrical harnesses.

- Incorporate Drip Loops into wiring designs (see Figure below). The pump connectors are environmentally sealed. However, good wire management can help ensure a good seal over the life of the product



Wire routing provides a path for water to flow down into connector



Drip loop collects water and sheds it away from connectors

- The use of Dielectric Grease such as Dow Corning DC-4 is acceptable as long as the connection is mated directly after grease application to prevent dirt from being captured by the grease

Installation

Orientation Specific

For orientation specific pumps, acceptable pump orientations are tied to the individual pump part numbers. The part number includes the motor stator for the appropriate voltage, the controller circuit board, and the vent port configuration.

Vertical Controller Orientation

Part numbers for this orientation include:

1030002275, 1030002278, 1030002280, 1030002283, 1030002285, 1030002287, 1030085013, 1030085016, 1030085018, 1030085019, 1030085021, 1030085023

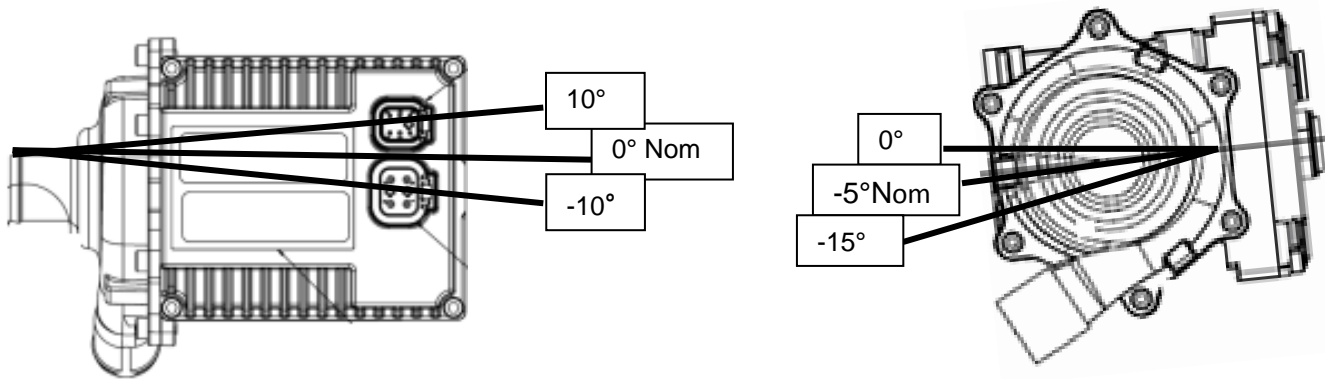

Horizontal Controller Orientation

Part numbers for this orientation include:

1030002276, 1030002277, 1030002279, 1030002284, 1030002286, 1030002288, 1030085014, 1030085015, 1030085017, 1030085020, 1030085022, 1030085024

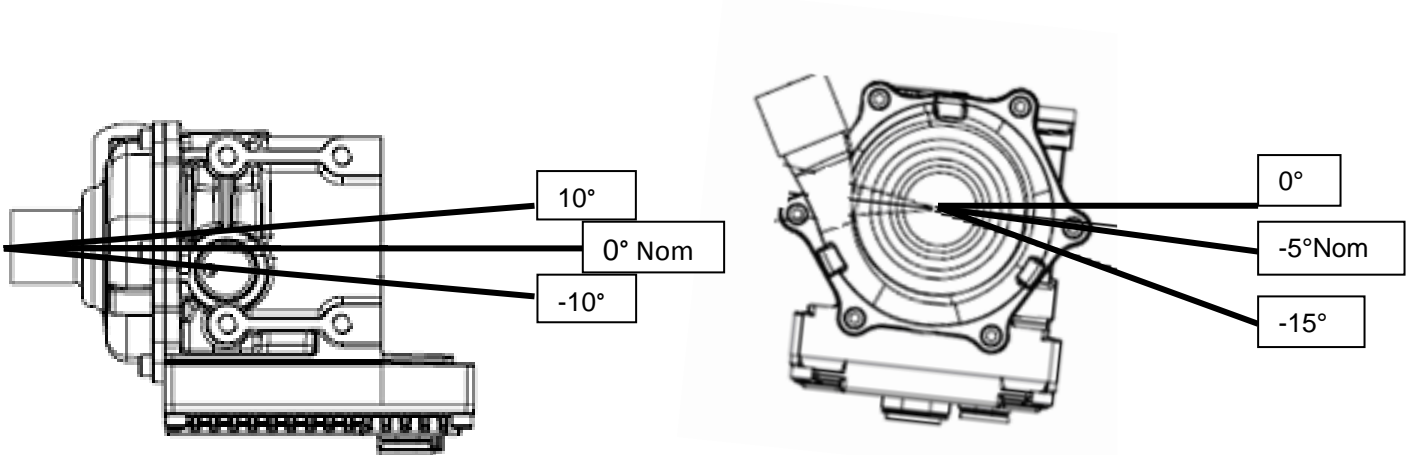

Dual Orientation

Part Numbers Include: 1030002225, 1030002228, 1030002229, 1030002230, 1030002231, 1030002232, 1030002237, 1030002247 thru 1030002251, 1030085001 thru 1030085012

The Dual Orientation pumps cannot be mounted at any arbitrary angle (i.e. 45 deg off axis). Standard Service pumps can use either the Vertical or Horizontal Orientations listed on the previous page.

Incorrect Pump Orientation and Reasons

The WP29 and WP32 contain a mechanical seal; 0.1cc/hr may weep past the seal as a part of normal operation. To properly collect the weepage pump orientation is important. Too steep of an angle will not allow the fluid to collect in the weep pocket and evaporate off and the pump may appear to be leaking when in fact it is operating as designed. An incorrect mounting angle may also result in too much fluid being retained in the weep pocket resulting in bearing contamination and reduced service life.

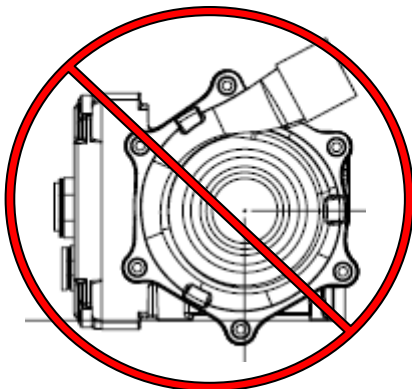

**Not Acceptable Orientation
No Weep Collection**

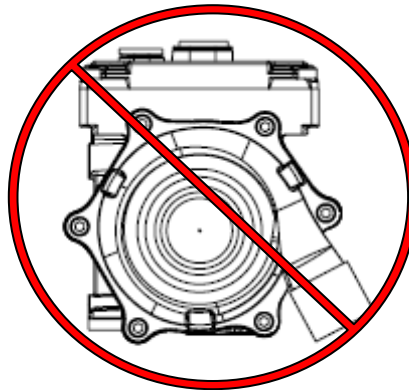

**Not Acceptable Orientation
Water in Connectors**

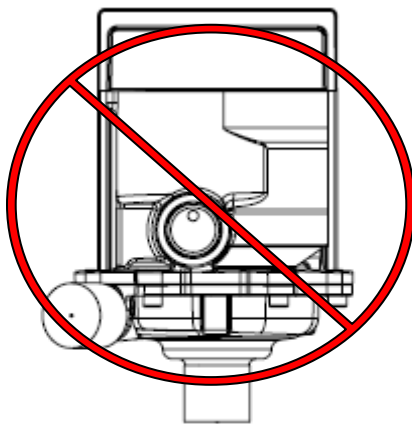

**Not Acceptable Orientation
Seal Life**

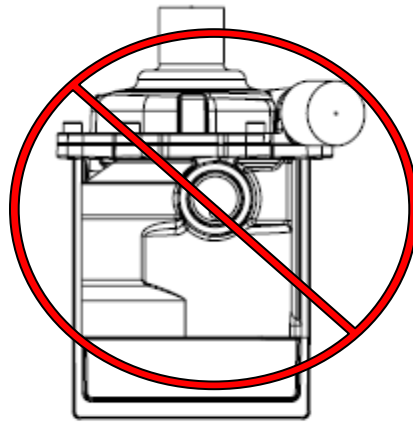

**Not Acceptable Orientation
Bearing Life**

Physical Inspection

CAUTION: DO NOT RUN THE PUMP WITHOUT FLUID PRESENT. IF RUN DRY EVEN FOR A SHORT PERIOD THE SEAL WILL BE DAMAGED.

1. Make sure the weep hole ports are not clogged with debris. If weep holes are plugged then open them up.

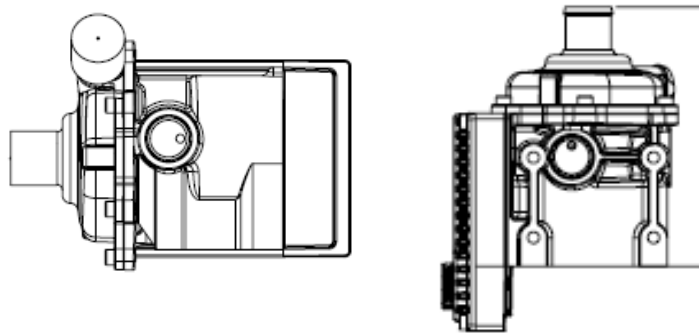

Weep Hole Ports

2. While the pump is connected to the bus, remove the 6 pin plug and connect the TTL adapter and turn the bus and heating switches "on" (to enable pump).
 - a. 24V power and IGN must be supplied to pump or it will not connect to the service tool.
 - b. Use EMPOwer Connect™ Service Tool to verify that the pump is on and running at correct speed.
3. Evaluate the pump for abnormal noises during operation. This is a subjective evaluation, vibration is not grinding; the user is looking for a noticeable bearing noise.
4. Observe the pump and area for leaking coolant. Fluid pouring out of the weep hole would indicate a failed mechanical seal. Dampness around the weep pocket is acceptable.

NOTE: COOLANT MAY BE SEEN OUTSIDE THE EMP WP29 ELECTRIC WATER PUMP. Mechanical Seal design requires fluid between the shaft and the seal material. This fluid vaporizes and passes the seal, venting through the weep collection pocket. As the seal wears in, the amount of venting decreases but never to zero.

In properly oriented pumps, the vapor will harmlessly evaporate unless the outside surfaces are cool enough to condense the vapors, which **may** result in a small volume of coolant visible on the exterior of the weep holes

There are two weep holes that vent from the same cavity. One will be capped with a solid plug, the other with a cap with two holes. If the pump seals are leaking excessively, fluid will come through the holes.

Acceptable Leakage

Depending on pump installation orientation, pumps may show up to 10 cc external leakage during the first 100 hours. In the preferred orientation, about half this amount may have external leakage. 10 cc coolant will make a small puddle approximately 4 inches across on a flat surface.

Troubleshooting

Symptom	Check
Pump not running.	<ul style="list-style-type: none"> • Check electrical connections • Check ignition wire • Check if ignition wire is “on” • Verify pin location
Pump is running but not pumping fluid.	<ul style="list-style-type: none"> • Check system fluid level • Check for tubing restrictions (kinks) • Make sure pump is primed • Check for collapsed inlet or outlet hose • Check pump inlet for trapped debris
No CAN communication and/or pump not responding to CAN commands	<ul style="list-style-type: none"> • Check communication harness wiring. • Verify that CAN messages are being transmitted in the proper formats (see online Technical Guide or contact EMP Technical Support for CAN message details). • Verify that the proper component CAN address is being used.
Pump bearings are making a grinding noise when running	<ul style="list-style-type: none"> • Replace pump
Pump is leaking excessively while running	<ul style="list-style-type: none"> • Replace pump. No action is required by customers for pumps exhibiting acceptable leakage as described

EMPower Connect™ Service Tool

Monitoring operation and manual control of the pump can be accomplished using the service tool EMPower Connect which is part of the EMP Service Suite available at no cost on our website at: <http://www.emp-corp.com/support/downloads/> . To use EMPower Connect download and install on your PC. If the pump is being run standalone you will also need an interface cable from the 6 pin Deutsch connector on the pump and an EMP USB/TTL converter. Both are available as a kit P/N 7500038001. If the pump is on a J1939 CAN bus EMPower Connect™ can be run using a Data Link Adapter (DLA) to interface to the CAN bus.

A user guide for EMPower Connect™ can be found here: <http://www.emp-corp.com/support/documents/>

Appendix A, WP29 and WP32 Installation Testing

The information provided in this document supplements the Installation Approval document and provides detailed information for service tool use with the WP29 and WP32. The information within this document may be helpful in developing unique system calibrations and mapping the operation of the cooling system.

Equipment Required for WP29 and WP32 Data Collection

1. Computer with the EMPower Connect service tool software installed.
2. Computer Interface Hardware with the WP29 and WP32
 - a. Using DLA: EMP Harness 3180001080 (may need power for DLA)
 - b. Using an EMP TTL: Service Tool EMP Kit # 7500038001
3. Data Acquisition Equipment Capabilities:

Pump Inlet Pressure	Required	-15 psi to 30 psi
Pump Outlet Pressure	Recommended	0 psi to 50 psi
Pump Inlet or Outlet Temperature	Required	0°C to 100°C
EMP Service Tool	Required	Pump Speed Control, Pump Current Measurement, Pump Voltage
Circuit Flow	Optional	Ensure Flow meter does not generate a restriction in the system.

4. For inlet pressure measured within one inch of the pump inlet, a special test pump with an instrumented inlet is available from EMP for installation approval testing. Contact EMP Engineering for access to the test pump (shown below).



Inlet Pressure Measurement Test Procedure

1. Install Instrumented WP29 and WP32 into the system.
 - a. If a non-instrumented WP29 and WP32 is to be used with an external sensor, ensure the sensor is located within 2 inches of the pump inlet and 4 inches from the last bend in the supply plumbing.
2. Application Simulation:
 - a. The pump shall be tested under the worst case conditions for the intended application.
 - b. If used in a pressurized system, test with the system pressure cap open to atmosphere
 - c. If used in a system where supplemental flow is provided, test at the minimum anticipated supplemental system operation.
 - d. If possible, test at the highest anticipated fluid temperature.
3. Operate the pump using the service tool manual control, press F2 to connect
4. Once connected, go to the “Dash” by selecting F3 or the F3-Dash button on the service tool banner. This will provide the following screen for the component control.

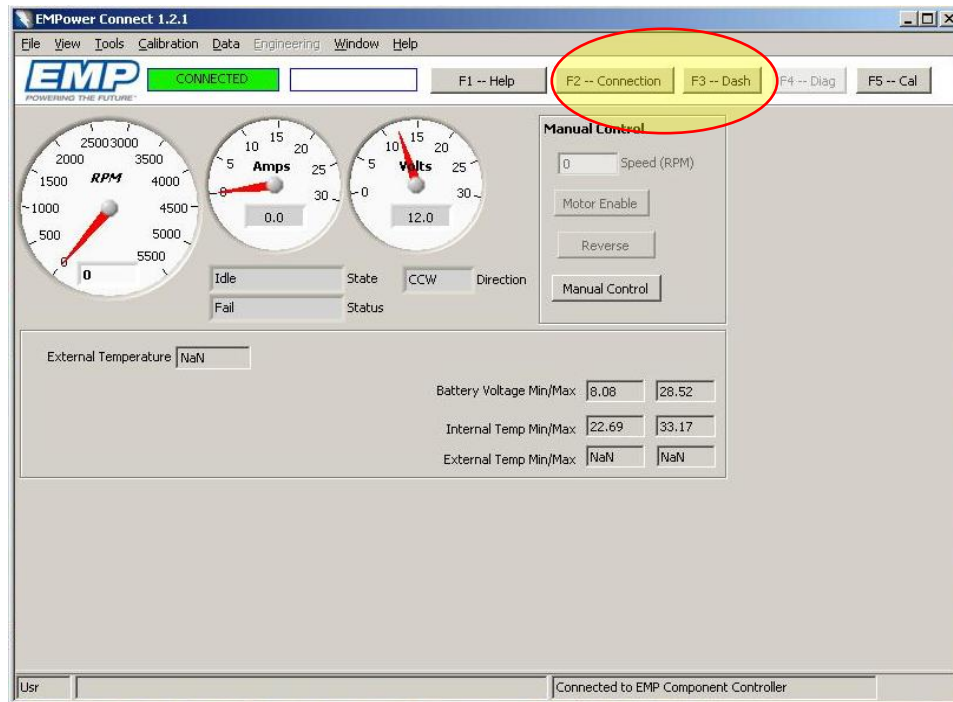

5. To manually control the WP29 and WP32 pump speed:

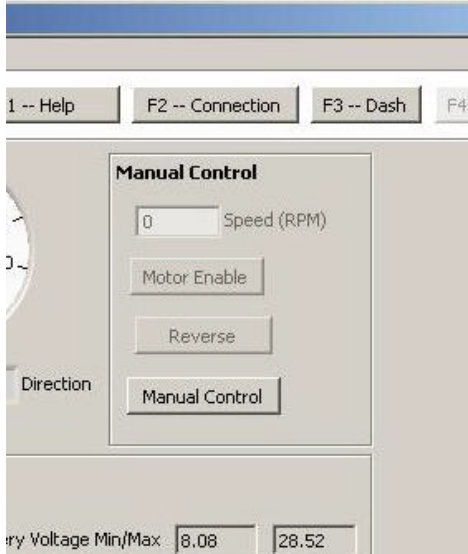

Step 1 Select **“Manual Control”** button

Step 2 Select **“Motor Enable”** button

Step 3 Enter pump test point speed

Press the enter button

Step 4 Record Test Data on the Installation Data Sheet

Step 5 Adjust pump speed for the next data point and record test data. Repeat step5 until matrix is complete.

Step 6 Select **“Manual Control”** button to return to normal operation. Motor Enable and Reverse will be grey as shown in the image.

6. Record the requested test information in the data sheets below.

Test Data Log Sheet

Installation Description
Pump Hardware & Software Numbers (Label)
Fluid Type
Unit or Vehicle Description and #
Coolant Type
Evaluation Date
Evaluation Location
Evaluator Contact Information

NOTE: Controller Settings from EMPower Connect service tool
Calibration Tab, View Calibrations

Customer Calibrations	Value
LV_MOTOR_RPM_MIN	
LV_MOTOR_RPM_MAX	
LV_MOTOR_MAX_CURRENT	
LV_MOTOR_RPM_DEFAULT	
LV_CAN_ADDRESS	
LV_CAN_FUNCTION	
LV_CAN_MSG_TIMEOUT	
LV_CAN_BASE ADDRESS	
LV_POWER_SHUTDOWN_TIME	
LV_TK_FAN_SPEED_SETPOINT	
LV_TK_FAN_TIME_REVERSAL	
LV_TK_FAN_REVERSAL_INTERVAL	
LV_TK_FAN_REVERSE_AT_START	
LV_TK_FAN_TEMP_MIN	
LV_TK_FAN_TEMP_MAX	
LV_TK_FAN_TEMP_HYST	
LV_TK_FAN_TEMP_BINS	

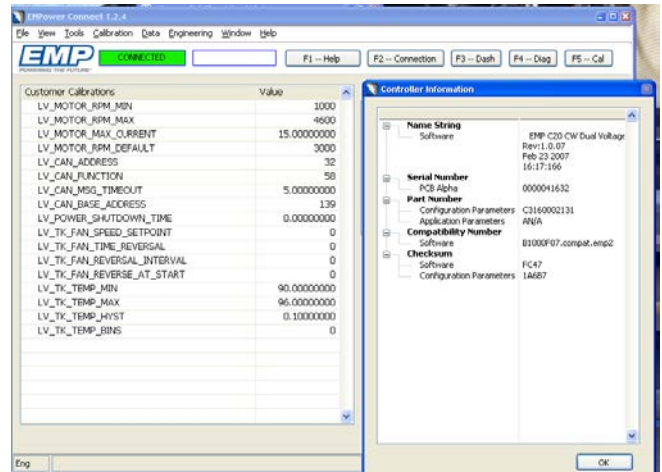

Installation Description
Test Configuration
Special Conditions:

Test Data Log

Pump Speed (rpm)	0	1000	2000	3000	3500	4000	4300	4600
Pump Current (Amps)								
Pump Voltage (VDC)								
Inlet Pressure (kPa/psi)								
Inlet/Outlet Temperature (F/C)								
Outlet Pressure (optional)								
Flow (optional)								

NOTE: *If the pump is being used in conjunction with another source of coolant flow (e.g. HVAC Boost Pump) perform measurements at worst and nominal operating conditions.*

NOTE: *Complete and submit a log page for each inlet or operational condition with the installation registration information.*

Appendix B, WP29 and WP32 Installation Approval Registration and Check Sheet

Submit Completed Forms to:
EMP
 2701 North 30th Street
 Escanaba, Michigan 49829
 Phone: 906-789-7497
www.emp-corp.com
Service@emp-corp.com

To be Completed by EMP

Installation Approval #
Date Submitted
Reviewer
Approval Date
Approval Signature
Comments

To Be Completed By Customer/Reviewer

Organization	Product Information
Street	Pump Hardware Number
City	
State/Prov	Pump Hardware Serial Number
Country	
Zip Code	Pump Programmed Assembly (PA) Number
Contact	
Phone	
email	

Installation Description, (Vehicle Type, Fluid Type, Mounting Location, Flow Requirements)

I certify that the pump will be used in as described in this installation approval request. I understand that any deviation from use as described here may void the warranty on the pump.

Requestor Name	Request Date
Requestor Signature	

Product Installation Questionnaire

Reference Section	Input Requirement	Input Met?		Reference Document(s) and/or Comments
		Yes	No	
Specifications - Performance	Do the flow and pressure curves match the system requirements?			
Specifications - Limitations	Is the maximum system fluid temperature (at the pump inlet) less than or equal to 95°C?			
Specifications - Limitations	Is the maximum ambient temperature less than or equal to 95°C?			
Specifications - Limitations	Is the minimum system fluid temperature (at the pump inlet) greater than or equal to -40°C?			
Specifications - Limitations	Is the minimum ambient temperature greater than or equal to -40°C?			
Specifications - Limitations	Is the application vibration enveloped by the EMPTS009 profile?			
Specifications - Limitations	Is the pump's mounting bracket .187" thick or greater? Does the bracket natural frequency exceed 150 Hz (with the pump mounted)?			
Specifications - Limitations	Are any bracket resonances or other audible abnormalities observed when the pump is run through the range of operating speeds?			
Specifications - Limitations	Is the pump located where there is a minimum 13mm (1/2 inch) clearance to ensure no rubbing or interference?			
Specifications - Limitations	Is the pump located away from external heat sources and direct road spray?			
Specifications - Limitations	If pump is exposed to external heat and road spray, is proper shielding in place to protect the pump?			
Specifications - Limitations	If the pump is exposed to road spray, is the correct pump orientation (horizontal/vertical) and part number being used (severe service)?			
Specifications - Approved Fluids	Is the system fluid on the approved fluids list? Provide fluid information and spec sheet.			
Specifications - Approved Fluids	Is the proper shaft material selected for the fluid used in the application (stainless steel vs carbon steel)			
Specifications - Electrical	Does the application meet the voltage and current requirements			
Specifications - Electrical	Is there a fluid level warning and/or switch to prevent dry operation of the pump? List the type of system used			
Specifications - Electrical	Are the power and ground wires a minimum of 12 AWG wire?			

Reference Section	Input Requirement	Input Met?		Reference Document(s) and/or Comments
		Yes	No	
Specifications - Electrical	Is the positive power wire fused at 30 amps within 6 inches of the voltage source?			
Specifications - Electrical	Is the ignition (key switch power) fused from the source or was an additional 5 amp fuse added to the ignition wire within 6 inches of the ignition source? Identify ignition source.			
Specifications - Electrical	Is the Ignition wire a minimum of 16 AWG?			
Specifications - Electrical	Is the power connected directly to the battery and the wake/sleep of the pump controlled by the enable signal? This is required for proper history and fault data storage.			
Specifications - Electrical	If the pump is not CAN controlled, is the 6 pin connector capped and contain all 6 cavity plugs?			
Specifications - Electrical	If the pump is CAN Controlled, is the CAN harness potted and are provisions made to seal the shield wire?			
Specifications - Electrical	If the pump is CAN Controlled, is the pump PA # properly specified for J1939 communication (J1939 address, CAN timeout, baud rate, etc)?			
Specifications - Electrical	Power and Plug installed and locked in position, no stress on the wires at connectors?			
Specifications - Electrical	Are electrical cables shielded if within 6 inches of an external heat source?			
Specifications - Electrical	Are electrical cables supported to prevent wear and abrasion to the cables?			
Installation - Orientation	Is the pump left to right angular orientation 5° to 15° downward to allow proper weep hole drainage?			
Installation - Orientation	Is the pump front to back angular orientation ±10° to allow proper weep hole drainage?			
Installation - Orientation	Is there a feature on the pump mounting structure to collect the small amount of weep that may escape the pump?			
Installation - Plumbing	Are the inlet and outlet hoses aligned and supported to reduce loading on the pump and bracket?			
Installation - Plumbing	Are the hoses/tubes supported to reduce the risk of rubbing?			
Installation - Plumbing	Is the WP29 and WP32 inlet plumbing one inch internal diameter from the coolant source?			
Installation - Plumbing	Are there 2-3 diameters of straight plumbing directly before the inlet of the WP29 and WP32?			
Installation - Plumbing	Is the WP29 and WP32 inlet plumbing “downhill” from the coolant source?			

Reference Section	Input Requirement	Input Met?		Reference Document(s) and/or Comments
		Yes	No	
Installation - Plumbing	Are there any elevated areas in the inlet supply? NOTE: Areas where air can be trapped and prevent coolant flow to the pump. The WP29 and WP32 is not a self-priming pump.			
Installation - Plumbing	Is the WP29 and WP32 more than 6 inches below the low fluid level?			
Installation - Plumbing	Is the inlet pressure greater than -5psig at maximum operating speed?			
Installation - Plumbing	Are there any filters or soft plumbing that could increase inlet restriction over time?			
Installation - Mounting	Are proper fasteners M8x1.25 used with lock washers and flat washers?			
Installation - Mounting	Do the fasteners have 12.7±1 mm (0.5±0.05 inch) engagement into the pump? NOTE: Mounting holes are threaded to 15mm (0.59 inch) depth.			
Installation - Mounting	Are the fasteners torqued to the 20±2 Nm (15±1.5 ft-lbs) specification?			
Installation - Fault Codes	Are any J1939 feedback parameters other than motor speed being used for system diagnostics?			
Installation - Requirements	Have the environmental limitations and the installation requirements outlined in 9970002273 been reviewed and agreed to?			
	Please describe the systems reaction to a WP29 and WP32 fault. (e.g. immediate stop, reduced performance, limited time to operate, system fault code etc..)			
	If CAN controlled list the CAN messages used for diagnostics			



Engineered Machined Products Inc.

2701 North 30th Street
Escanaba, Michigan 49829
Phone: 906-789-7497
www.emp-corp.com
Service@emp-corp.com