

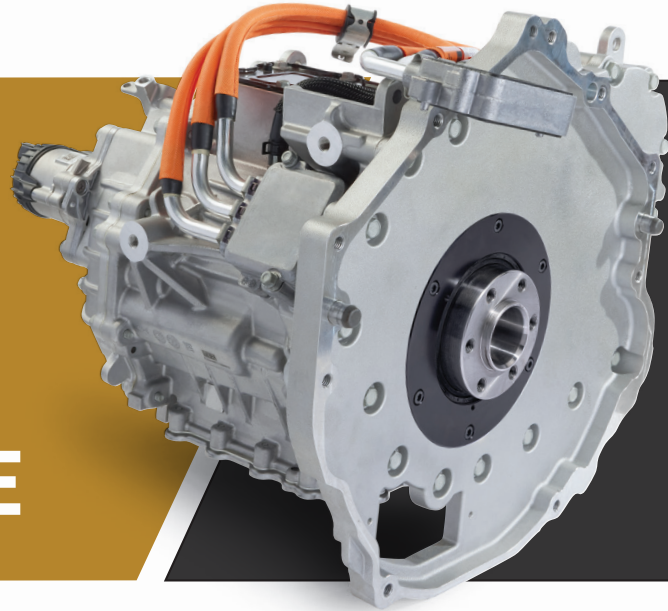

PERFORMANCE

eCrate 400v/200hp

# CHEVROLET PERFORMANCE eCRATE PLUGS INTO THE FUTURE



## All-new kit is Chevrolet's first-ever battery/motor system for EV conversions

Chevrolet Performance, which helped pioneer the high-performance crate engine and introduced the innovative Connect & Cruise crate engine kits, takes the next step into the future with the all-new eCrate system—its first-ever battery/motor system designed for electric-vehicle conversions.

The new eCrate system offers builders a comprehensive kit that includes the primary elements for converting conventional combustion-engine-powered vehicles into fully electric propulsion. Its production-based components include a 66 kWh lithium-ion battery pack and a 400-volt electric drive motor that's designed to bolt up to most conventional GM transmissions.

Additional supporting components include a thermal management system, the charging receptacle, control modules and more.

### System highlights include:

- A 66 kWh production-based lithium-ion battery pack, including thermal and battery management systems
- A 400-volt electric drive motor capable of 266 lb.-ft. of torque (360 Nm) and 200 horsepower (150 kW) of motoring power
- Charging receptacle and charge cord set
- Accelerator pedal
- Thermal management system with air conditioning compressor, cabin heater and more
- High Voltage Power Electronics and supporting high-voltage cables
- Low-voltage harnesses and controllers
- Additional supporting components and hardware

**IMPORTANT!** Chevrolet Performance's eCrate system is only available through approved installation centers (Available mid-2023 in limited quantities).

Visit [www.chevrolet.com/performance](http://www.chevrolet.com/performance) for availability and a list of certified installers.

### eCRATE DRIVE MOTOR

The Chevrolet Performance eCrate Drive Motor is a three-phase AC permanent-magnet motor that is capable of producing up to 266 lb.-ft. of torque (360 Nm) and 200 horsepower (150 kW) of motoring power. The motor is designed to connect directly to a GM 4-speed automatic transmission with an external mode switch. That simplifies the installation process, allowing installers to retain a more conventional drivetrain layout, with the drive motor replacing the combustion engine under the hood. The electric motor offers almost instantaneous torque making the drive a lot more fun than traditional ICE powered vehicles.

### SPECIFICATIONS:

Name:	400 Volt Automotive Drive Motor
Motor:	Synchronous permanent magnet AC
Power:	200 hp / 150 kW
Torque:	266 lb.-ft. / 360 Nm
Battery Options:	66 kWh / 400V
Additional Features:	Can be mounted to a standard GM crate transmission
Cooling	Liquid cooled

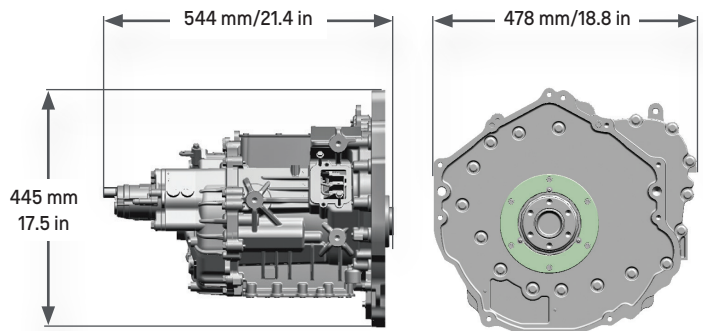

CARB EO#: B-88

This part is 50 state emissions street legal when installed and used as described in the CARB executive order.

Visit [www.chevrolet.com/performance-parts/emissions](http://www.chevrolet.com/performance-parts/emissions) for more details.

Chevrolet Performance eCrate systems have been granted official California Air Resources Board (CARB) E.O. numbers, making them street legal for installation in MY2000 and older light-duty cars and trucks with a GVWR ≤ 6000 lb. in all 50 states.

## eCRATE BATTERY PACK

The new Chevrolet Performance eCrate 66 kWh (400V) lithium-ion battery pack offers great power in a one-piece low-profile design that can be adapted to a variety of applications. It employs production-based thermal management and battery management systems, for easier plug-and-play operation with the available control modules.

### SPECIFICATIONS:

Height at front:	7.3 in. (185 mm)
Height at rear:	13.7 in. (347 mm)
Overall width:	50.2 in. (1276 mm)
Overall length:	71.1 in. (1807 mm)
Weight:	947 lb. (430 kg)

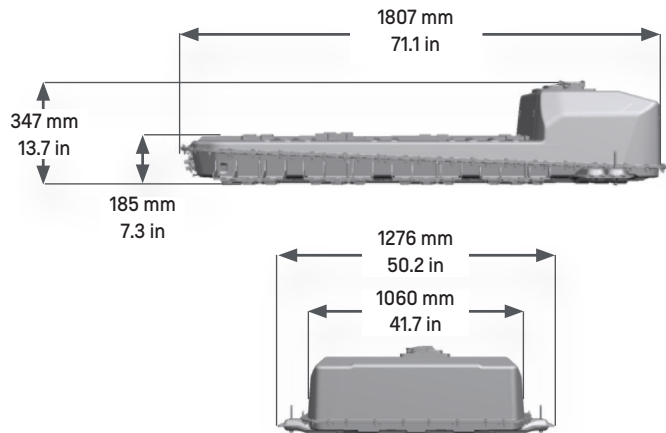

## eCRATE CONTROL MODULES & ACCESSORIES

Along with the production-based battery pack and drive motor, engineers developed electrification propulsion kits for converting conventional combustion vehicles into fully electric vehicles. They're designed with existing GM technology and components, providing builders with more of the components they need to complete a retro-fit installation and get the vehicle on the road sooner.

### High-Voltage Power Electronics

- Power inverter
- On-board charger module
- Auxiliary power module
- High-power distribution module
- Battery heater
- Electric AC compressor
- Cabin heater

### Low-Voltage Power Electronics

- Electronic control module and low-voltage harnesses
- Vehicle Integration Control Module
- Additional associated control modules

### & Accessories

- Charging receptacle
- Level 1 charge cord
- Accelerator pedal

### Optional Components

- Power steering pump
- Brake vacuum pump
- Dual level charge cord set – P/N 85163382
- Installation kit for transmission – P/N 19433630

### Additional Components

**NOTE:** Information may vary with application. All specifications listed are based on the latest product information available at the time of publication. The right is reserved to make changes at any time without notice. ©2023 General Motors. All rights reserved. The marks appearing in this ad are the trademarks or service marks of GM, its subsidiaries, affiliates, or licensors.

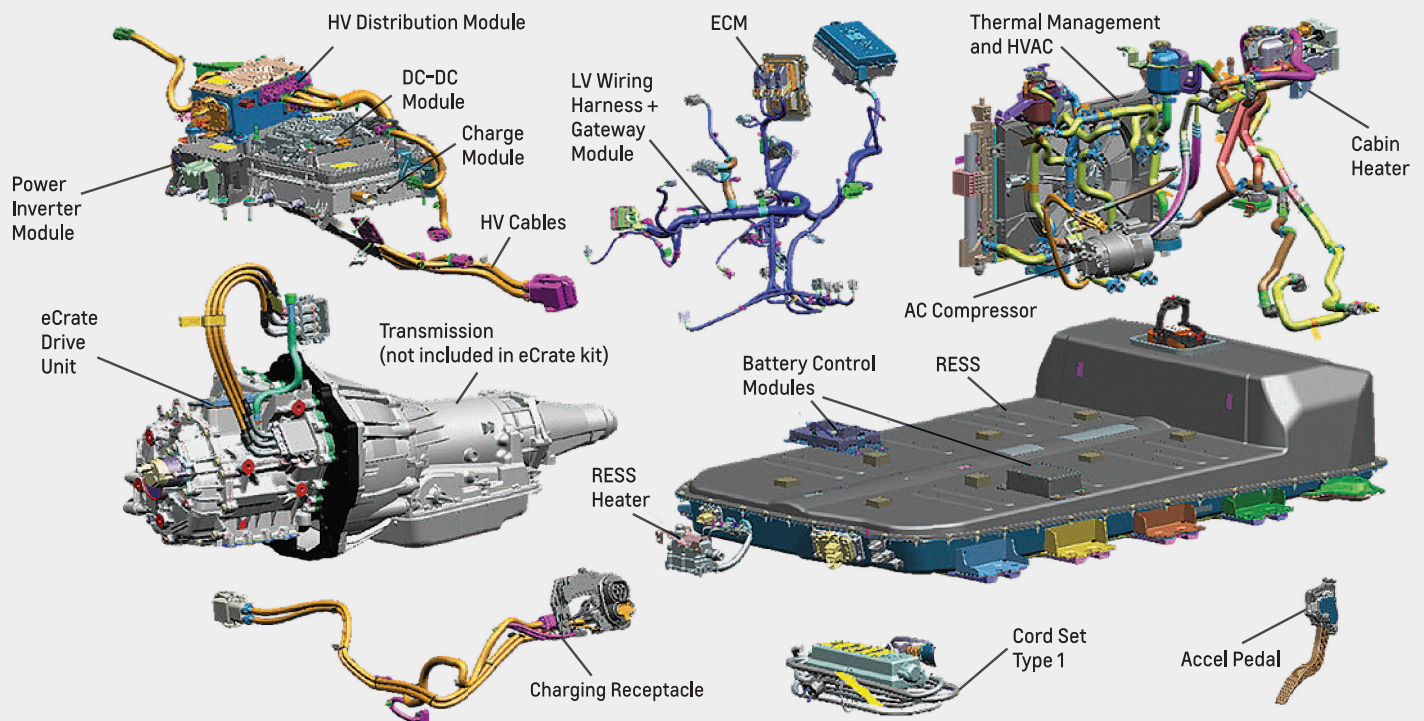

PERFORMANCE

Follow Chevrolet Performance: @ChevroletPerformance



WATCH



FOLLOW



LIKE