

LNC-TRM Torque Reduction Module Installation Instructions

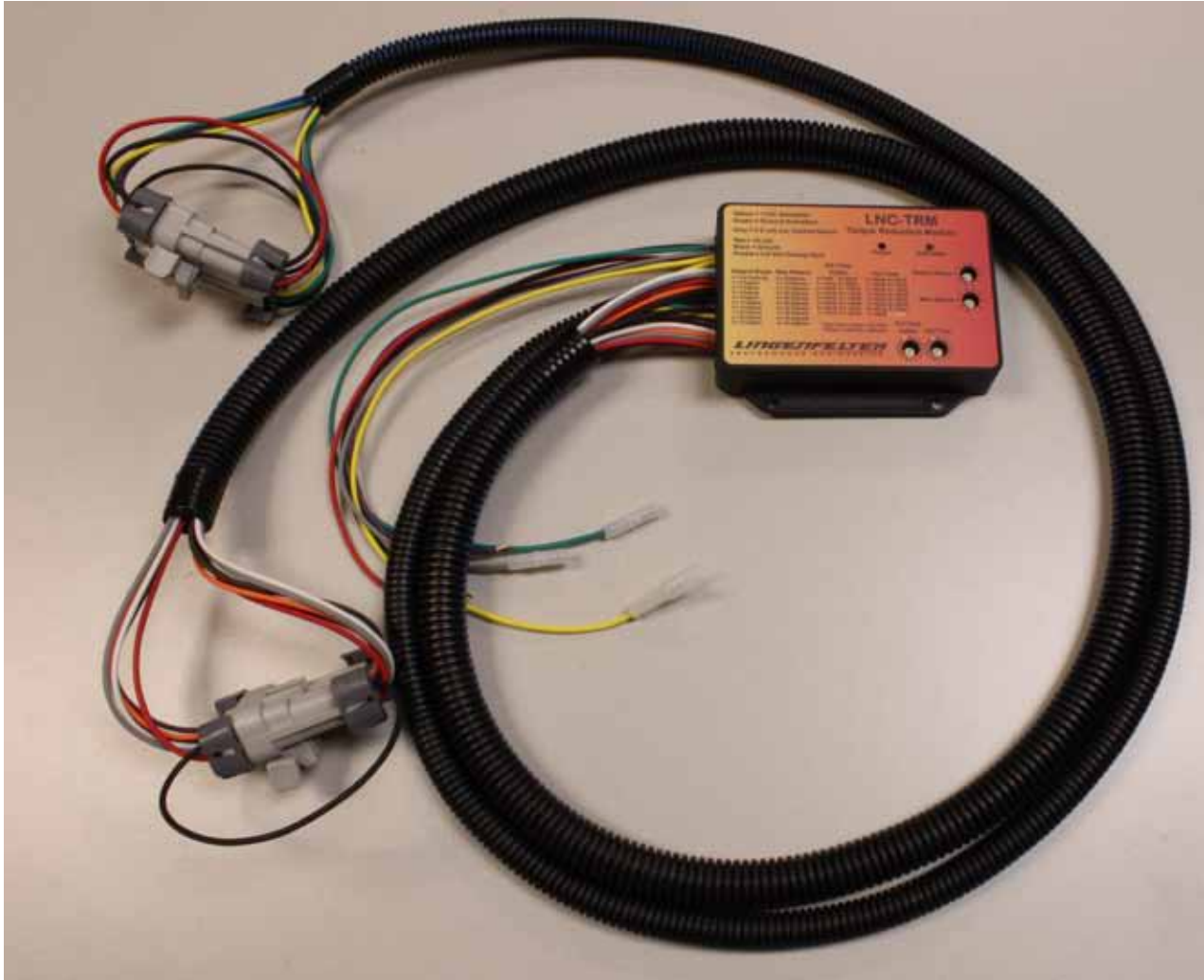

PN: L460285297 & L460316109

Lingenfelter Performance Engineering
1557 Winchester Road
Decatur, Indiana 46733
(260) 724-2552 phone
(260) 724-8761 fax
www.lingenfelter.com

Release date: 17 July 2015

L460285297 (LNC-TRM) Parts List*

#	Part number	Description
1	LNC-TRM	LPE Torque Reduction Module
1		72" trigger wire harness
7	06483	Hook and loop tape, per inch
4	AV16037	Self tapping screws
1	L950050000	LPE technician's screwdriver
2	L920180000	LPE bumper sticker & sponsor decal
1		Instructions

L460316109 (LNC-TRM-LS9A) Parts List*

#	Part number	Description
1	LNC-TRM-LS9A	LPE Torque Reduction Module for LS9 & LSA applications
1		72" trigger wire harness
7	06483	Hook and loop tape, per inch
4	AV16037	Self tapping screws
1	L950050000	LPE technician's screwdriver
2	L920180000	LPE bumper sticker & sponsor decal
1		Instructions

Optional Items

Description	Part Number
Transient voltage suppression (TVS) diode kit	L450080000
LED for indicator light	
• Red 12 vdc LED with 30 cm leads	L450030000
• Green 12 vdc LED with 30 cm leads	L450040000
Sealed 40 amp heavy duty relay kit	L450100000
Red LED lighted paddle toggle switch, 20 amp	DC-7600500

Additional items to connect to Davis Technologies modules:

#	Part number	Description
1	12015793	3 pin Weather Pack connector
3	15324982	Wire seal, 2.03-2.85mm wire
3	12089188	Female terminal, 18-20 AWG
1	12010300	Cavity plug

* The LNC-TRM is not designed for use with the LSA and LS9 engine combined coil pack/fuel injector harness connectors. A version of the LNC-TRM is available for those applications, LNC-TRM-LS9A. This module is a custom order part available on request and is not normally kept in inventory.

LINGENFELTER

PERFORMANCE ENGINEERING

LNC-TRM Specifications:

- Custom molded glass filled Nylon 6 high temperature enclosure.
- 40 MHz 16-bit automotive qualified processor with eight channel Enhanced Time Module.
- Independent coil drive.
- Each coil drive circuit has a dedicated timer to keep the timing accurate over the full RPM range.
- Reverse battery protection.
- Both of the activation inputs have active clamps and optical isolation to suppress electrical noise from external solenoids (such as trans brake and line lock).
- Digital filter provided in software to further isolate electrical noise on the activation inputs.
- Separate switches for easy setting adjustments.
- Direct access to the controller settings without requiring removal of a cover or access panel.
- Both **Ground Activation** and **+12 Volt Activation** digital inputs are provided for torque reduction activation.
- 0-5 Volt analog input for external torque reduction control
- 0-5 Volt analog voltage output for sending applied retard signal to data acquisition systems (EFILive, HPTuners, DashDAQ, Racepak, AEM, AIM, etc.).
- True plug-and-play coil pack connection design for ease of installation and removal.
- Fully encapsulated (potted) construction for added durability.
- One year warranty (from date of purchase).



LNC-TRM description:

The LNC-TRM, or Torque Reduction Module, is a timing retard controller designed to be used on GM Gen III & IV V8 engines with OEM engine management systems. This includes such engines as the LS1, LS6, LS2, LS3 and LS7. The LNC-TRM provides adjustable timing retard control with up to 50 degrees of timing retard authority. This timing retard can be used to reduce engine torque for external traction control systems or to perform a momentary torque reduction event during a gear change. The length of the torque reduction event can be controlled by the LNC-TRM or it can be controlled by an external device including traction control modules, nitrous controllers, or transmission controllers.

The LNC-TRM reduces engine torque via ignition timing retard, not via an ignition cut. This makes it compatible with gear shift torque reduction strategies on vehicles equipped with catalyts.

NOTE - if you are looking for a timing retard controller purely for nitrous or turbocharged/supercharged applications and 15 degrees of timing retard authority is enough then you may want to consider the LNC-2000 (PN L460145297) instead of the LNC-TRM.

WARNINGS:

DO NOT place in direct exposure to exhaust manifolds, turbocharger turbine housings or other underhood items that are high temperature heat sources (radiated heat sources). The warranty does not cover damage due to melted enclosures or wiring due to improper installation.

Do NOT submerge Controller in liquid or directly wash unit with liquid of any type! The switches on the LNC-TRM are sealed but are NOT rated for high pressure wash, use caution if power washing near the LNC-TRM controller

Important Information regarding spark plug wires and spark plugs:

You must use noise suppression ignition wires AND resistor type spark plugs with this Controller. The LNC-TRM Controller contains High Frequency Digital Electronics and will NOT function correctly without Noise Suppression Wires or resistor type spark plugs!

Note: The LNC-TRM receives power and ground from the coil pack connectors. The +12V and ground activation wires are not power and ground for the controller.

Indicator lights and switches:

Red (Power) LED:

- Comes on solid on start-up (power on)

Green (Activation) LED:

- Off if no retard is active
- Solid green for the duration of the timer if either digital input active
- Blinking green if analog input active

Torque reduction settings:

- Timing retard controlled by two 10 position switches and two 16 position switches
 - **Retard Slope** (*Switch #1, 10 position switch*)
 - Sets the slope for the rate of change in timing retard for ramp in/ramp out
 - Rate of retard is in number of degrees added/removed per cylinder event (**see Appendix A**)
 - Controls the slope in and out (same slope is used for both ramp out and ramp in)

Position	Degrees Per Cyl Event
0	0 (no ramp)
1	2
2	4
3	6
4	8
5	10
6	15
7	20
8	25
9	30

- **Max Retard** (*Switch #2, 10 position switch*)
 - Sets the maximum degrees of timing retard

Position	Max Degrees
0	5
1	10
2	15
3	20
4	25
5	30
6	35
7	40
8	45
9	50



- **Kill Time** (*Switch #3, 16 position switch*)
 - Sets the duration of the torque reduction (timing retard) event in milliseconds (ms)
 - Setting (F) indicates to the module that the torque reduction event is continuously on whenever input 1 or 2 (digital inputs) is active
 - Setting (F) is used when an external device controls the duration of the torque reduction events via the digital inputs (green or yellow wire)

Position	Time (ms)
0	25
1	30
2	35
3	40
4	45
5	50
6	55
7	60
8	65
9	70
A	75
B	80
C	85
D	90
E	95
F	OFF

- **Kill Time Addder** (*Switch #4, 16 position switch*)
 - Adds to the amount of Kill Time set by switch #3.

Position	Time (ms)
0	0
1	10
2	20
3	30
4	40
5	50
6	60
7	70
8	80
9	90
A	100
B	110
C	120
D	130
E	140
F	150

Activation/input wires:

- Input 1
 - Green input wire
 - “Ground activation”
 - On/off type activation wire (digital input)
 - This wire activates the torque reduction whenever a ground is applied to it
 - Unless “Kill Time” is in position “F” this input does not impact the duration of the torque reduction event, just when it starts to occur
 - Can be activated via a momentary switch
 - Releasing the digital input does not end the torque reduction event.
- Input 2
 - Yellow input wire
 - “+12 volt Activation”
 - On/off type activation wire (digital input)
 - This wire activates the torque reduction whenever +12 volts are applied to it.
 - Unless “Kill Time” is in position “F” this input does not impact the duration of the torque reduction event, just when it starts to occur
 - Can be activated via a momentary switch
 - Releasing the digital input does not end the torque reduction event.
- Input 3
 - Purple input wire
 - “0-5 Volt Analog Input”
 - 0 to 5 volt variable input (analog input)
 - This input allows an external device to control the amount of timing retard (torque reduction).
 - 0-5 volts = 0-50 degrees of timing retard
 - 0.1 volts per degree, minimum 5 degrees=0.5 volts
 - Minimum retard of 5 degrees
 - Considered active above 0.5 volts
 - Anything below 0.5 volts is ignored (no retard)
 - Timing retard is active for as long as Analog Input is active (above 0.5 volts)
 - Ramp in and ramp out rate of timing retard still controlled by “Retard Slope” setting
 - Maximum amount of timing retard still limited by “Max Retard” setting
 - “Kill Time” and “Kill Time Adder” settings do not apply to this input
 - Input 3 over-rides digital inputs 1 & 2
 - The LNC-TRM scans the analog input voltage first. If a valid voltage is present, it ignores the digital inputs.

Other wiring:

- Coil harness connections (2x)
 - Standard GM Gen III & IV coil pack connections
 - Does not matter which bank you connect each connector to
- Gray output wire
 - “Applied Retard”
 - Indicates the amount of timing retard
 - Does not currently take into account time limitations on spark retard below 2778 RPM so below that RPM it can report values in excess of what is actually possible.
 - 0-5 volts = 0 to 50 degrees
- Black wire
 - Sensor ground if a load cell input or other similar sensor is used
 - Can also be used as a logic ground between the LNC-TRM and an external device to make sure the two devices are at the same ground reference.
- Red wire
 - +5 volts
 - For shift lever load cell or other sensor power supply
 - Note - sensor output to the LNC-TRM has to be a 0-5 volt output, it can't be a 2.5 volt centering type signal like that used on the LNC-TC1 torque cut module

Notes:

- **Changes to the switch point settings (Retard Slope, Max Retard, Kill Time, Kill Time Adder) require the unit to be powered down for the changes to become active**

- **The switch positions are ONLY read on start up**

- The LNC-TRM timing reduction can be activated at any RPM
- At low RPM the maximum amount of timing retard the LNC-TRM is able to achieve is based on the maximum amount of time it can delay a cylinder firing event (0.0030 seconds). This means that below 2778 RPM the maximum amount of timing retard available is less than 50 degrees. At or above 2778 RPM the maximum timing retard is fixed at 50 degrees. Below that RPM the maximum amount of timing retard available is as follows:

RPM	500	750	1000	1250	1500	1750	2000	2500	2778	3000+
Degrees	9	13.5	18	22.5	27	31.5	36	45	50	50

- If you have the Max Retard switch set to a timing retard value higher than what can be achieved, the LNC-TRM will only provide amount of timing retard that is possible (as shown in the table above). If the Max Retard switch is set to a lower timing retard value than the table value then the amount of timing retard will not exceed that value.
- The length of time the digital activation input is connected does not impact the length of the torque reduction event unless “Kill Time” is in position “F” (OFF).
- You must disconnect/disable the digital input to reset the torque reduction event and be able to trigger a new torque reduction event.
 - If the two digital inputs are directly connected to each other (green to yellow wire) then a single torque reduction event will occur on initial start-up and then the two wires will need to be disconnected from each other to reset the system and allow another torque reduction event to occur.

Installation:

- Make sure the ignition is off before beginning installation.
- You can mount the LNC-TRM using the supplied hook and loop tape or the supplied self tapping screws.
- Do NOT mount the LNC-TRM directly on top of the engine or near the exhaust manifolds due to heat concerns.
- Do NOT mount the LNC-TRM in the line of site of high temperature objects such as exhaust manifolds, turbine housings etc. If needed, put a heat shield in between the heat source and the module.
- Do NOT install within 6" of nitrous solenoids or other devices with strong magnetic fields.
- If you have relocated coil packs, do not run the high voltage spark plug wires alongside the low voltage coil pack wires. Keep the wires as far apart as possible and, if they do have to intersect, have them intersect at right angles.
- Keep the activation wires and the analog voltage input wire (purple wire) away from possible sources of electrical noise (coils, injectors, etc.)
- Disconnect the pack connectors on each side of the engine and then plug the LNC-TRM wiring harnesses in between on each side. It does not matter which bank of cylinders each side of the LNC-TRM harness connects to.



Torque reduction activation:

- How you plan to activate and control the torque reduction events will dictate how you wire the activation/control wires.
- If you want to use a momentary switch to activate the torque reduction event (timing retard) and then have the dials on the LNC-TRM control how much timing is removed and for how long then all you need to do is wire a momentary switch to the yellow (+12 volt activation) or green (ground activation). If you don't have a ground source or +12 volt source you want to use you can also wire the momentary switch in between the yellow and green wires. Then you set the switches for the Retard Slope, Maximum Retard and Kill Time you want to occur each time you activate the input.
- If you want to manually control how long the timing retard event lasts but allow the switches on the LNC-TRM to control the amount of timing retard then you would wire in a switch to the green or yellow wire as above but then you would set the "Kill Time" switch to position "F". The timing retard will then be active for as long as you have the switch active (connected to ground or +12 volt depending on how you have it wired).
 - This would also be how you would wire the LNC-TRM if you wanted an external device to control it via a simple switched output. An example would be a timer output from a time delay box or a nitrous controller.
- If you want an external device to control when the timing retard becomes active and how much timing is taken out then do not connect anything to either of the digital inputs (green or yellow wire). Connect the 0-5 Volt output from the device that is going to control the timing to the purple input wire on the LNC-TRM. We also recommend connecting the black ground wire to the ground signal of the external device so that the two modules are using a common ground (to reduce the changes of a voltage offset between the two devices).
 - Examples of what might be connected to this input would be:
 - External traction control devices like the Davis Technologies modules (see wiring diagrams on pages 17 and 18)
 - LPE NCC-002 nitrous controller when performing progressive timing retard (see page 16)
 - Transmission controller performing a torque cut during a gear change event



Vehicle applications:

LNC-TRM (part # L460285297):

The LNC-TRM is designed for use on most known GM LS series engine applications. This includes the LS1, LS6, LS2, LS7, LS3, LQ4, L76, L92 and other Gen III and IV GM V8 applications (along with other GM V8 engines using the same ignition coil system) including the following vehicles:

- 1997-2004 C5 Corvette
- 2005-2013 C6 Corvette (including Z06)
- 1998-2002 LS1 V8 equipped Camaro and Firebird
- 2004-2006 Pontiac GTO
- 2008-2009 Pontiac G8 with the L76 or the LS3 engine
- 2011-2013 Caprice PPV
- 2004-2007 Cadillac CTS-V
- 1999-2013 GM CK trucks (Tahoe, Yukon, Escalade, H2, Sierra, Silverado, Avalanche) with the 4.8, 5.3, 6.0 and 6.2L Gen III and IV V8 engines (will not work on 305 & 350 Vortec engines)
- 2003-2006 Chevrolet SSR
- 2006-2009 Trailblazer SS and other S/T body trucks with the 4.8, 5.3 and 6.0L Gen III & IV GM V8 engines
- Holden and export model Chevrolet vehicles based off of the Holden models equipped with Gen III & IV V8 engines (Caprice, Commodore, etc.)
- Front wheel drive 5.3L LS4 Gen IV V8 equipped cars (Impala SS, Grand Prix & Monte Carlo)
- CK trucks with 8.1L V8 engines (L19) with individual coil ignitions

The LNC-TRM should also function with these products but has not yet been tested with them:

- Aftermarket coils for the LS series engines (such as the MSD coils) used with GM ECM/PCM.
- Aftermarket engine management systems and ignition systems (Accel, BigStuff3, FAST, Holley, MEFI, Motec, MSD, etc.) that run the production GM coils.

LNC-TRM-LS9A (part # L460316109):

The LNC-TRM-LS9A is specifically designed for use on the 2009-2013 ZR1 Corvette (LS9 engine), the 2009-2014 Cadillac CTS-V (LSA engine) and the 2012-2014 ZL1 Camaro (LSA engine). These applications need a different module because the LS9 and the LSA engines use a combined coil and fuel injector harness resulting in a different harness connector.

The LNC-TRM will NOT work with other individual coil ignition systems like those found on the GM Northstar or Ecotec engines or on the Ford modular V8 and the Chrysler Hemi V8.

Neither product is designed to work with the new 2014+ Gen V GM V8 direct injection engines (LT1, L86, L83). LPE is working on versions of the LNC products for these applications. Contact LPE for more details.

Additional Notes

Important Information regarding spark plug wires and spark plugs:

You must use noise suppression ignition wires AND resistor type spark plugs with this Controller. The LNC-TRM controller contains High Frequency Digital Electronics and will NOT function correctly without Noise Suppression Wires or resistor type spark plugs!

Nitrous, line-lock, trans-brake and other solenoid usage warning:

LPE has found that these solenoids can cause fly-back voltage levels at times in excess of 600 volts. These voltage levels have the potential to damage sensitive electronics including the LNC-TRM, the PCM/ECM and other modules in the vehicle. LPE has developed a transient voltage suppression (TVS) diode kit (PN L450080000) for use with line-lock solenoids, trans-brake solenoids and other aftermarket automotive solenoids of this type. The TVS diode is a special kind of diode used to suppress voltage spikes.

Install the TVS diode across the solenoid wires as close to the solenoid as possible. Polarity does not matter (Red and Black wires can go to either solenoid wire). If there is no accessible ground terminal to connect the diode to, as is the case with many trans-brake solenoids, the diode should be connected to the nearest ground source. In the case of the diode for the trans-brake solenoid, the diode should be connected to the transmission case as it will provide a ground path.

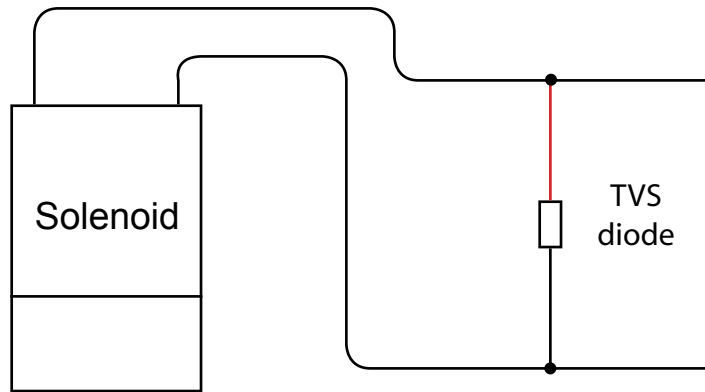

LPE recommends using TVS diodes on:

- Nitrous solenoids
- Nitrous purge solenoids
- Fuel solenoids
- Line-lock solenoids
- Trans-brake solenoids

Troubleshooting:

- Intermittent misfire or other erratic vehicle operation.
 - Have someone monitor the LED's on the LNC and note what they are doing when the problem occurs. Try changing the settings on the LNC. Does the problem still occur and, if so, to the same extent and for the same duration?
 - Disconnect the digital activation input or the analog signal input and retest (leaving the LNC connected to the coil packs)
 - Does the problem still occur?
 - If no, the problem is likely coming from the activation input.
 - Check for an erratic activation signal or electrical noise on the activation input. Are you using a microswitch or momentary switch? Bypass this device to confirm that it isn't giving you erratic activation signals. Are you using a mechanical relay in a high vibration/acceleration environment? If so, try switching to a solid state relay.
 - If the problem still occurs, disconnect the LNC from the vehicle completely (activation, and coils) and test again.
 - If the problem still occurs, it is not related to the LNC.
 - If the problem goes away, re-install the LNC and test the following:
 - Re-route the LNC wiring harness away from the spark plug wires and/or ignition coils.
 - Make sure the wires are not run in parallel with electrical wiring including fuel injector harness wires or nitrous solenoid wires.
 - Mount the LNC in a different location.
 - If you are using aftermarket spark plug wires, try changing back to the stock spark plug wires or a different brand of spark plug wires. Make sure you are using noise suppression spark plug wires.
 - If you are using aftermarket/non OEM spark plugs, confirm that they are really a resistor type plug.
 - If you can't get resistor spark plugs in the heat range or design you need, try installing resistor type spark plug boots on your spark plug wires (available from NGK)
 - No power LED on LNC/no vehicle start up
 - Try disconnecting everything and plugging it all back in - you may have corroded or loose connections. Inspect all connectors and wires for damage and wear.
 - Torque reduction always active or torque reduction not working
 - Check what the LED's on the LNC are doing when the torque reduction should become active
 - Make sure that the LNC ground activation wire is not connected to an "always on" ground. This connection is not a module ground but an activation ground.
 - Make sure you don't have the yellow and green activation wires connected directly to each other - this will cause the LNC to either be active on each key up cycle, or if the "Kill Time" is set to "F", to always be on.
 - Check what the voltage levels are at the red, black and purple wires
 - Check what the Applied Retard output signal using a volt meter on the gray analog out wire.

Appendix A - Retard Slope

Rate of retard vs cylinder event (# of degrees added/removed per cylinder event)

0 (no ramp), 2, 4, 6, 8, 10, 15, 20, 25 & 30 degrees per cylinder event

Table of Change in Ignition Timing vs RPM and Retard Slope setting in Degrees per millisecond (shown in red):

	RPM	1000	2000	3000	4000	5000	6000	7000	
	events/ second =	67	133	200	267	333	400	467	
Retard slope (deg/cyl event)	0	NA	NA	NA	NA	NA	NA	NA	degrees per ms
	2	0.1	0.3	0.4	0.5	0.7	0.8	0.9	
	4	0.3	0.5	0.8	1.1	1.3	1.6	1.9	
	6	0.4	0.8	1.2	1.6	2.0	2.4	2.8	
	8	0.5	1.1	1.6	2.1	2.7	3.2	3.7	
	10	0.7	1.3	2.0	2.7	3.3	4.0	4.7	
	15	1.0	2.0	3.0	4.0	5.0	6.0	7.0	
	20	1.3	2.7	4.0	5.3	6.7	8.0	9.3	
	25	1.7	3.3	5.0	6.7	8.3	10.0	11.7	
30	2.0	4.0	6.0	8.0	10.0	12.0	14.0		

Table of Time Required to Ramp Timing Vs RPM and Retard Slope setting (for max retard at that RPM point) in seconds (shown in red):

	RPM	1000	2000	3000	4000	5000	6000	7000	
	Max retard =	18	36	50	50	50	50	50	
Retard slope (deg/cyl event)	0	NA	NA	NA	NA	NA	NA	NA	seconds for max degrees ramp (to ramp in or out to full amount of timing retard)
	2	0.135	0.135	0.125	0.094	0.075	0.063	0.054	
	4	0.068	0.068	0.063	0.047	0.038	0.031	0.027	
	6	0.045	0.045	0.042	0.031	0.025	0.021	0.018	
	8	0.034	0.034	0.031	0.023	0.019	0.016	0.013	
	10	0.027	0.027	0.025	0.019	0.015	0.013	0.011	
	15	0.018	0.018	0.017	0.013	0.010	0.008	0.007	
	20	0.014	0.014	0.013	0.009	0.008	0.006	0.005	
	25	0.011	0.011	0.010	0.008	0.006	0.005	0.004	
30	0.009	0.009	0.008	0.006	0.005	0.004	0.004		

NOTICES:

It is the responsibility of the purchaser to follow all guidelines and safety procedures supplied with this product and any other manufacturer's product used with this product. It is also the responsibility of the purchaser to determine compatibility of this device with the vehicle and other components.

Lingenfelter Performance Engineering assumes no responsibility for damages resulting from accident, improper installation, misuse, abuse, improper operation, lack of reasonable care, or all previously stated reasons due to incompatibility with other manufacturer's products.

Lingenfelter Performance Engineering assumes no responsibility or liability for damages incurred from the use of products manufactured or sold by Lingenfelter Performance Engineering on vehicles used for competition racing. Lingenfelter Performance Engineering neither recommends nor approves the use of products manufactured or sold by Lingenfelter Performance Engineering on vehicles which may be driven on public highways or roads, and assumes no responsibility for damages incurred from such use.

It is the purchaser's responsibility to check the state and local laws and sanctioning body requirements pertaining to the use of this product for racing applications. Lingenfelter Performance Engineering does not recommend nor condone the use of its products for illegal street racing.

Limited Warranty:

LPE warrants the Lingenfelter LNC-TRM Launch Control Module to be free from defects in material and workmanship under normal use and if properly installed for a period of one year from date of purchase. If the module is found to be defective as mentioned above, it will be replaced or repaired if returned prepaid along with proof of date of purchase. This shall constitute the sole remedy of the purchaser and the sole liability of LPE. To the extent permitted by law, the foregoing is exclusive and in lieu of all other warranties or representations whether expressed or implied, including any implied warranty of merchantability or fitness. In no event shall LPE be liable for special or consequential damages.

Progressive Nitrous Timing Retard

To allow a nitrous or other external device to control the amount of timing retard and when it occurs:

- Set the LNC-TRM to the desired Retard Slope using switch #1
- Set the LNC-TRM to the desired Maximum Retard using switch #2
- Connect the analog output from your external device to the purple analog input wire on the LNC-TRM
- This allows the nitrous or other external controller to control the amount of timing retard while still allowing the LNC-TRM to limit the timing retard to the user set Max Retard setting.

NOTE - with the analog input voltage going to the purple input wire, the yellow and the green activation inputs are ignored and the Kill Time and the Kill Time Adder are also ignored when ever a voltage of above 0.5 volts is sent to that input.

Lingenfelter NCC-002 Nitrous Control Center Connected to the LNC-TRM Torque Reduction Module for Progressive Timing Retard

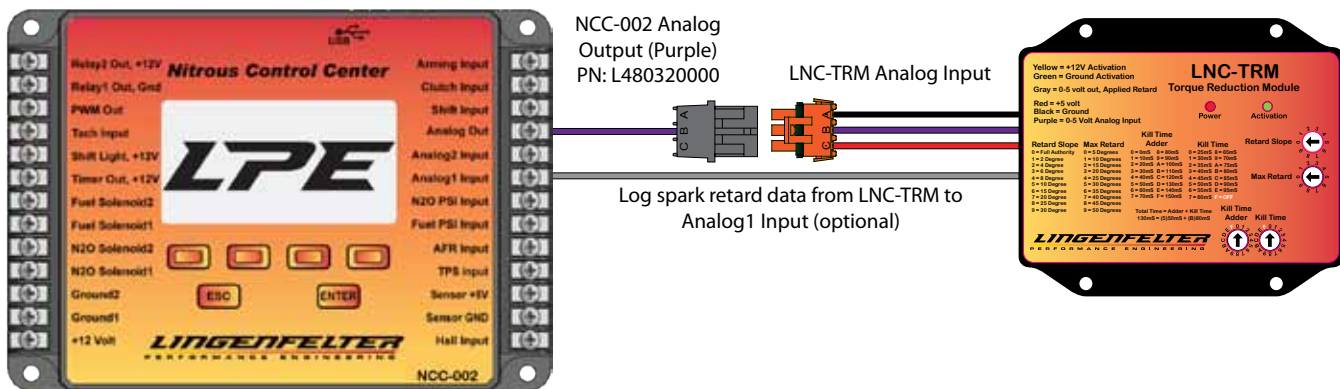

LINGENFELTER

PERFORMANCE ENGINEERING

LNC-TRM Receiving 0-5V Timing Retard Input from a Davis Technologies TMS-Drag-MAP Series Traction Control Module (With the MAP Adapter)

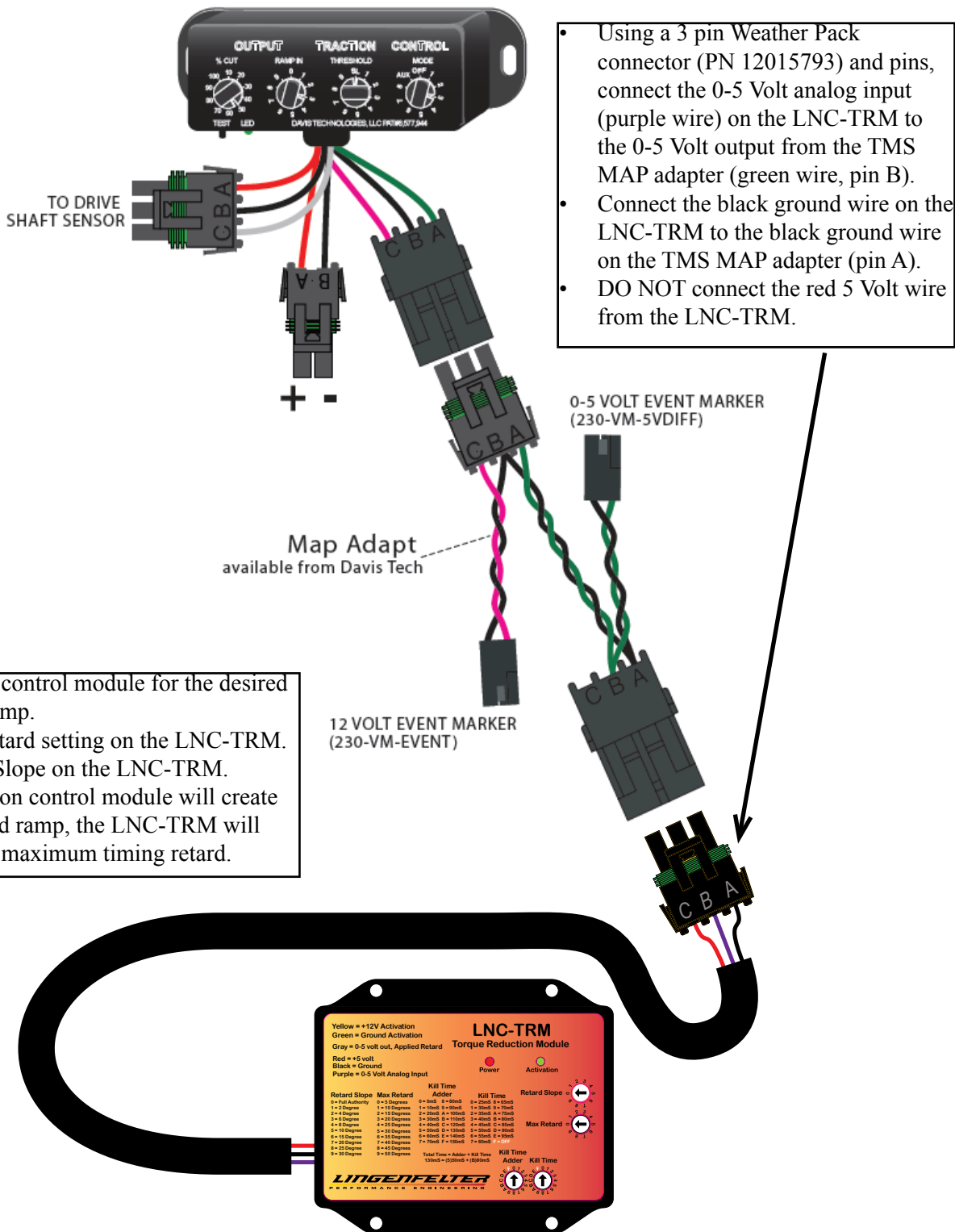

- Set the traction control module for the desired timing retard ramp.
- Set the Max Retard setting on the LNC-TRM.
- Set the Retard Slope on the LNC-TRM.
- While the traction control module will create the timing retard ramp, the LNC-TRM will still control the maximum timing retard.

LNC-TRM Receiving 0-5V Timing Retard Input from a Davis Technologies TMS-Drag-MAP Series Traction Control Module (Without the MAP Adapter)

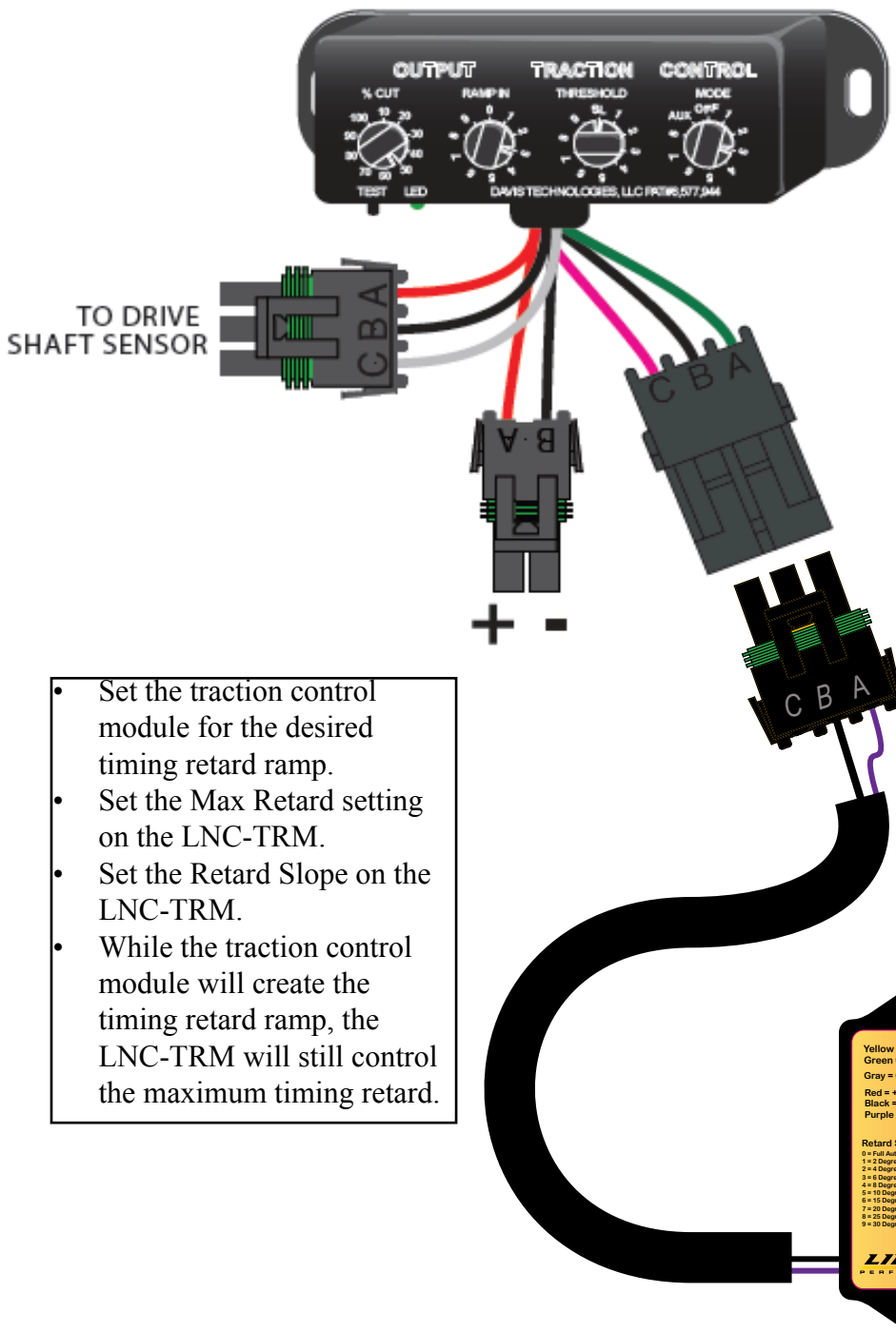

- Using a 3 pin Weather Pack connector (PN 12015793) and pins, connect the 0-5 Volt analog input (purple wire) on the LNC-TRM to the 0-5 Volt output from the TMS (green wire, pin A).
- Connect the black ground wire on the LNC-TRM to the black ground wire on the TMS (pin B).
- DO NOT connect the red 5 Volt wire from the LNC-TRM (use a cavity plug to seal that position in the connector).

- Set the traction control module for the desired timing retard ramp.
- Set the Max Retard setting on the LNC-TRM.
- Set the Retard Slope on the LNC-TRM.
- While the traction control module will create the timing retard ramp, the LNC-TRM will still control the maximum timing retard.

LNC-TRM
Torque Reduction Module

Yellow = +12V Activation
Green = Ground Activation
Gray = 0-5 volt out, Applied Retard
Red = +5 volt
Black = Ground
Purple = 0-5 Volt Analog Input

Power (Red) Activation (Green)

Retard Slope	Max Retard	Adder	Kill Time	Retard Slope
0 = Full Authority	0 = 0 Degrees	0 = 0ms	0 = 250ms	0 = 0
1 = 2 Degree	1 = 10 Degrees	1 = 10ms	1 = 300ms	1 = 10
2 = 4 Degree	2 = 15 Degrees	2 = 20ms	2 = 350ms	2 = 20
3 = 6 Degree	3 = 20 Degrees	3 = 30ms	3 = 400ms	3 = 30
4 = 8 Degree	4 = 25 Degrees	4 = 40ms	4 = 450ms	4 = 40
5 = 10 Degree	5 = 30 Degrees	5 = 50ms	5 = 500ms	5 = 50
6 = 15 Degree	6 = 35 Degrees	6 = 60ms	6 = 550ms	6 = 60
7 = 20 Degree	7 = 40 Degrees	7 = 70ms	7 = 600ms	7 = 70
8 = 25 Degree	8 = 45 Degrees	8 = 80ms	8 = 650ms	8 = 80
9 = 30 Degree	9 = 50 Degrees	9 = 90ms	9 = 700ms	9 = 90

Total Time = Adder + Kill Time
130ms = (5)50ms + (8)80ms

LINGENFELTER
PERFORMANCE ENGINEERING

LINGENFELTER

P E R F O R M A N C E E N G I N E E R I N G

For additional product installation information and technical support, contact LPE or your LPE products distributor. You can also find technical support and usage discussions regarding this product and many other LPE products in our Internet forums:

<http://www.lingenfelter.com/LPEforumfiles>

Join us on Facebook!

<http://www.facebook.com/#!/lpehp>

Lingenfelter Performance Engineering
1557 Winchester Road
Decatur, Indiana 46733
(260) 724-2552 phone
(260) 724-8761 fax
www.lingenfelter.com